



Ateneo School of Government  
The Graduate School of Leadership and Public Service

# GOVERNMENTWATCH

JOINT GOVERNMENT-CITIZEN ACTION FOR GOOD GOVERNANCE

## Bayanihang Eskwela Manual:

A Guide to Citizen Monitoring of School Building Construction Projects





Ateneo School of Government  
The Graduate School of Leadership and Public Service

**GOVERNMENTWATCH**  
JOINT GOVERNMENT-CITIZEN ACTION FOR GOOD GOVERNANCE

# Bayanihang Eskwela Manual:

**A Guide to Citizen Monitoring of School Building Construction Projects**

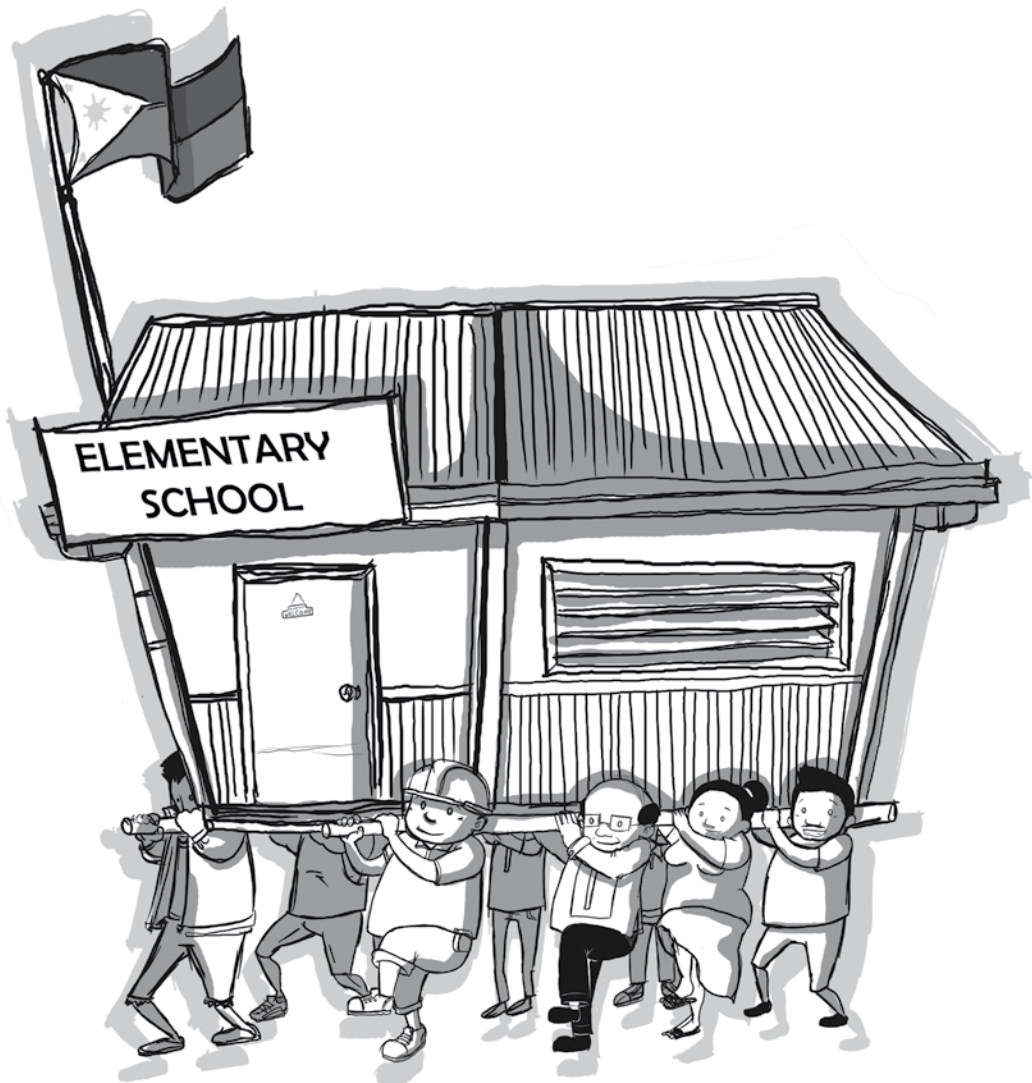

Philippines

## **Bayanihang Eskwela Manual: A Guide to Citizen Monitoring of School Building Construction Projects**

The Bayanihang Eskwela Manual is an easy-to-use toolkit that guides the setting and implementation of a community-based monitoring of government school building projects (SBP) using the tested processes and tools of Bayanihang Eskwela, a joint monitoring initiative of the Ateneo School of Government through its Government Watch Program, in partnership with the Department of Education, Department of Public Works and Highways (DPWH), the Girl Scouts of the Philippines, the Boy Scouts of the Philippines and the Office of the Ombudsman.

Recognizing that school building construction monitoring may seem daunting and technical, this Manual is made simple and easy-to-understand for any concerned citizen organization that wishes to engage DepEd and DPWH in monitoring school-building projects (SBP). It also aims to assist government project engineers in involving community participation in SBP implementation.

This publication has been made possible with funding support from the United Nations Development Programme Fostering Democratic Governance Portfolio through the facilitation of the Civil Service Commission.

The opinions expressed herein are those of the writer and do not necessarily reflect the views of the CSC and the UNDP.

The G-Watch Team is composed of the following people:

Project Director:

Joy G. Acheron

Team Members:

Rafaela Mae David  
Mars Dela Cueva  
Glenford Leonillo  
Phillip Don Recentes  
Rechie Tugawin

SOURCE: This manual is based from the three rounds of G-Watch's *Bayanihang Eskwela Project*, and from *G-Watch Guide – Your Partner in Monitoring Government Programs*

Illustrations and Cover Design by Egon Layson  
Book Design and Layout by Ray Leyesa

Published 2010

Introduction: Why the need for citizen participation in government school building program? .....	1
You and Your Government.....	2
Government Watch Model of Social Accountability.....	3
G-Watch’s Bayanihang Eskwela Initiative .....	5
Bayanihang Eskwela Manual: What You Should Expect from this Manual.....	6
 Part A: Bayanihang Eskwela Project Design: The Basics .....	7
 Part B: Organizing Your Community-based SBP Monitoring Team .....	9
Members of the Monitoring Team: .....	9
Setting up a Coordination and Communication System.....	10
Coordination .....	11
 Part C: Capacity Building of Community-based SBP Monitoring Teams .....	14
Briefing Orientations!.....	14
Component 1: Introduction to Bayanihang Eskwela .....	15
Component 2: Bayanihang Eskwela Checklist Training: .....	15
Component 3: Construction Monitoring Tips.....	16
Component 4: Planning Workshop .....	16
Learning by Doing! .....	17
 Part D: Monitoring Using the Bayanihang Eskwela Checklist .....	18
Format .....	18
Monitoring Stages .....	18
School Profile .....	20
Pre-Construction .....	21
Activity 1: Site Identification .....	21
Activity 2: Project Meeting .....	22
Activity 3: Pre-Engineering Survey .....	22
Activity 4: Preparation of Program of Works (POW) .....	23
Activity 5: Site Inspection .....	23
Activity 6: Bidding .....	24
Construction Stage.....	24
Activity 1: Earthworks and Excavation .....	26
Activity 2: Concrete Works .....	26
Activity 3: Masonry .....	26
Activity 4: Carpentry .....	26
Activity 5: Painting .....	29
Post-construction stage .....	30

Conduciveness to Learning .....	32
Responsiveness to School need .....	33
Part E: Processing Your Checklist and Generating Results .....	34
School profile .....	34
Pre-Construction, Construction and Post Construction Stage .....	35
Conduciveness to Learning and Responsiveness to School Need ..	38
Making sense of your data .....	39
Part F: Reporting and Communicating Outcomes .....	40
Quick Response Feedback Mechanism .....	40
Reporting After the Monitoring .....	40
Sharing Session .....	41
Problem-Solving Session: Making the Decision-Makers Responsive .....	41
Annexes .....	43
Annex 1: Bayanihan Eskwela Checklist .....	44
Annex 2: Department of Education School Building Design .....	53
Annex 3: The Bayanihang Eskwela Processing Template .....	57





## INTRODUCTION

# Why the need for citizen participation in government school building program?

It's not hard to imagine a classroom filled with 60 or even more students, with leaking roofs, broken windows, and even cracked walls. That's because you can find these classrooms almost in every corner of the Philippines. In fact, DepEd projects that in 2011, there will be a shortage of 152,569 classrooms in the Philippines.<sup>1</sup> This reflects the persisting problem of overcrowded classrooms with a class of 60 to 70 packed like sardines in a classroom meant only for 45.

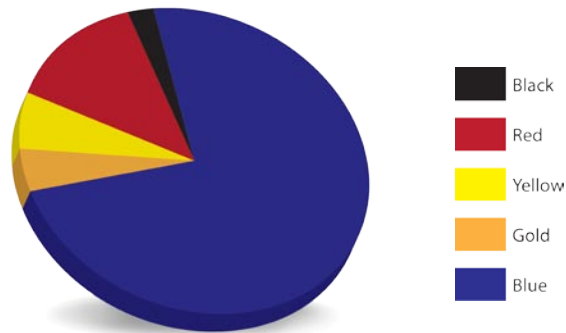

Figure 1. 2009 National Summary

Can you see the gold, blue, red and black parts of the pie figure above? That signifies that 25% (non-blue schools) of the total number of schools nationwide are experiencing classroom shortage.

Overcrowding not only makes it more difficult for the teacher to teach her students properly, it also prevents the students from more comfortably learning in school.

To help remedy the situation, the government has been implementing different school building programs. The major national school building programs include the Regular School Building Program implemented by the Department of Public Works and Highways and the Red and Black School Building Program of the Department of Education.

<sup>1</sup> Data from the Department of Education - Physical Facilities and Schools Engineering Division.

The oldest national initiative aimed to address school building shortage is the Regular School Building Program or RSBP implemented by the Department of Public Works and Highways. Albeit this has been helping address classroom shortage, it has proven to be insufficient. Thus the gap between the classroom need and the pace our government can respond is widening.

Thus in 2006, the Department of Education established their Red and Black School Building Program which will implement school building constructions in schools which are in dire need of schools buildings (Red and Black are the color categories of schools which have more than 55 students per classroom or no permanent classrooms at all).

Aside from these two, schools buildings are also implemented with the support of the Local Government Unit and of District Representatives.

Despite these programs however, the task of constructing more than a hundred thousand classrooms will be daunting. The meager resources of the government are not sufficient in addressing this shortage.

What is more disconcerting is that reports of substandard classrooms and even ghost classrooms still abound. Even with recent improvements in government systems, there remain abuses in a number of localities that lead to poor quality school buildings. That's why these classrooms would easily exhibit signs of wear and tear even only after a year or two.

The challenge then is to ensure that the resources are used well, and that leakages due to abuse and corruption are prevented. But how can one do this? This manual hopes to teach you just that: How can an ordinary school member make sure that his/her new classrooms are well built and free from corruption?

## YOU AND YOUR GOVERNMENT

As citizens, you and I are part of a bigger sphere that interact with, and in a way, dictate, how our government will be and will act. This means that whatever we do as individuals and as a collective affects how our government serves us. But how can we make sure we affect them in a positive way?

Government Watch believes that you can do this specifically by participating in governance –by helping account for government services and thus answer the question: *Is the government doing its job?*

Now, you can do this by informally observing government services. You may occasionally pass by a road construction which seems like it has been going on forever! So you go to your city hall and complain about the traffic that has constantly caused inconvenience to you and the hundreds of drivers and passengers passing by that road every day.

But more effectively, you can also do this by keenly and systematically checking if the services are done the way they should be according to project plans. For instance, you may obtain the annual plans of your municipal government and check whether they have accomplished their plans well.

This manual will teach you how to do the latter kind of engaging your government – this as you will see is a more proactive and constructive approach to checking whether your government is working or not. More specifically, it will teach you how to monitor school building construction, the G-Watch way.

## GOVERNMENT WATCH MODEL OF SOCIAL ACCOUNTABILITY

Year 2001, there were a plethora of reports on corruption that came out, including anomalies in the education sectors: Philippines as one of the most corrupt in Asia, billions of pesos lost in procurement-related corruption, and ghost projects in both textbook delivery and school-building projects.

Government Watch (G-Watch) was formed as a civil society response to address the worsening corruption.

G-Watch focused initially on basic service deliveries like health, education and social services, and later on specialized on education service delivery due to several factors: (1) the importance of education reform; (2) responsiveness of leaders in the Department of Education (DepEd); (3) G-Watch being a program of an academic institution (Ateneo School of Government).

In engaging the Department of Education, central is the social accountability approach or society-led effort to account for government action and decisions. The G-Watch social accountability approach, to be exact, means constructive engagement between government and citizens in performance monitoring.

G-Watch social accountability approach has the following features that worked in contributing to the improvement of education service delivery, particularly for textbooks and school-building constructions:



First, it is a joint citizen-government monitoring, hence by watching the government, we mean both the citizens and government officials watch or monitor a particular government process constructively or towards a common objective or goal of improving service delivery for better services received by the people.

Second, it is preventive and pre-emptive by clarifying the standards (processes, outputs, performance targets, etc.) of an on-going process that it monitors, hence serving as an affirmative action to ensure compliance to standards or to avoid deviations.

Third, it is community-based to empower the beneficiaries to ensure that the government actually does its job and delivers quality goods and services. Ensuring that monitoring is decentralized and localized also allows the initiatives to be embedded in the community life for sustainability.

Fourth, it builds the capacity of communities and citizens by developing easy-to-use monitoring tools with measurable performance indicators.

Fifth, it generates hard data and evidence that serve as bases for recommendations on how to improve the service delivery monitored.

Through these features, the G-Watch monitoring initiatives in the education department contributed to improvement in

governance by enhancing transparency, accountability and efficiency that resulted in better education services and goods provided to school children, which hopefully would lead to improvement in education outcomes.

### G-WATCH'S BAYANIHANG ESKWELA INITIATIVE

G-Watch has documented cases of poor implementation in school building projects, which appear to have been tolerated and perpetuated by corruption undetected by weak monitoring mechanisms.

To address this problem, the Government Watch of the Ateneo School of Government with Department of Public Works and Highways (DPWH), Department of Education (DepEd), Office of the Ombudsman (OMB) Girl Scouts of the Philippines and Boy Scouts of the Philippines (BSP) has been conducting *Bayanihang Eskwela*, a collaborative public-private sector program that aims to ensure quality school buildings for public school children, since 2006.

For its pilot run, the project has shown how ordinary citizens can monitor school building projects by using simple, non-technical tools and methods. By taking note of date and cost and some procedural, quantifiable and readily observable quality aspects, community monitoring teams were able to make an account of the condition of the project. Such account sufficed to validate or invalidate reports submitted by the implementers to the central office overseeing the project.

With the success of the pilot-test of *Bayanihang Eskwela*, two more rounds of implementation were conducted to cover other areas, specially the critical ones that would benefit most from a public-private community-based monitoring project. *Bayanihang Eskwela* thus expanded its initiative from Luzon, to different parts of Visayas and Mindanao.

This project was undertaken in collaboration with the Boy Scouts/ Girl Scouts of the Philippines (BSP/GSP) and the Parent-Teacher-Community Associations (PTCAs) in the target school building sites. The PTCAs have the natural interest with and stake on education-related matters, especially when it comes to the building or rebuilding of public schools that has a direct effect on the quality of education of local children.

Monitoring is an active involvement in the implementation of a project, which entails:

- watching the implementation with the main objective of the project in mind
- comparing the plan and standards with the actual accomplishments
- checking particular aspects of the project in its various stages
- recommending remedial actions, if necessary.

## BAYANIHANG ESKWELA MANUAL: WHAT YOU SHOULD EXPECT FROM THIS MANUAL

Learning from the experience of three rounds of Bayanihang Eskwela, this manual will teach you how you yourself can establish a similar kind of initiative in your own school,

This is an easy-to-use toolkit that will guide you in the setting and the implementation of your own community-based monitoring of government school building projects (SBP) using the tested processes and tools of Bayanihang Eskwela.

Recognizing that school building construction monitoring may seem daunting and technical, this manual is made simple and easy-to-understand for any concerned citizen organization that wishes to engage DepEd and DPWH in monitoring school-building projects (SBP). This manual will thus give you a step-by-step guide, from forming your team, to getting your government respond to your results.

Now, if you're reading this and planning to have your own community based SBP monitoring initiative, a word of warning must be said: Put your gears on, cause this ride will be "perspiring but inspiring!"

# Bayanihang Eskwela Project Design

Monitoring school building construction may seem like it's hard to do, but if you plan it well, it will surely be a fun and fruitful experience for you and your school community. All you need is a little guidance and surely, any of you and your friends can do it!

This manual will help you do just that! It will share to you how you can have your own Bayanihang Eskwela at your own school.

## BAYANIHANG ESKWELA PROJECT DESIGN: THE BASICS

Bayanihang Eskwela is designed specifically to facilitate effective community participation in ensuring quality school building projects. It prescribes five (5) specific stages for a successful monitoring project:

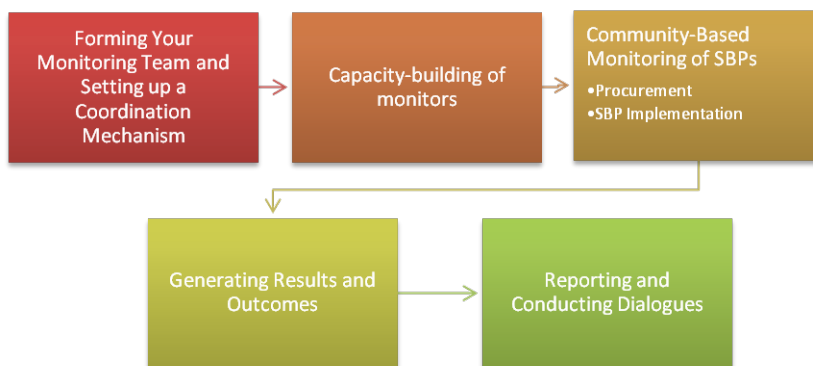

Diagram 1: Bayanihang Eskwela Project Design

This design will give you an overview of the important activities that shall be conducted and guide you in making your initiative more effective and thus far-reaching in terms of effectiveness and impact.

### **1. Forming your monitoring team!**

It's time to invite volunteers. Get people on board in this monitoring project. Solicit the participation of community members to become project stakeholders. This will serve as an opportunity for community members to contribute time, effort and resources that will benefit community especially the students.

## ***2. Capacity building of Community-based monitoring team***

After forming your team, you have to train them on how to effectively conduct a monitoring project. Invite a technical person such as the Physical Facilities Coordinator of your division to give you a briefer on this. Afterwards, plan how you will monitor the school building.

## ***3. Monitoring using the Bayanihang Eskwela checklist***

Find out how easy it is to monitor construction of school building using the Bayanihang Eskwela Checklist! For your guidance, this is an easy-to-use tool that has been prepared for you to make it easier to conduct your monitoring. Take pictures while monitoring and keep a journal to be able to document all your activities.

## ***4. Generating results and outcomes***

Once you're done with your monitoring, collect all checklists and generate the data. It's time to assess whether the school building construction has followed standards and produced the best results given the lowest cost.

## ***5. Reporting and Communicating Outcomes***

When you have finally generated your data, it is time to communicate it to your partners from the implementing agencies. For you to be able to produce results, you must be able to transmit the information you gathered to decision-makers inside government to be able to produce real outcomes in government systems.

Find the specific details and steps for these stages of your monitoring in the next sections of this manual. This manual will thus guide you in every phase of your Bayanihang Eskwela monitoring of government school building projects.

## Organizing Your Community-based SBP Monitoring Team

Before you start your monitoring, of course you first have to form your team. For you to do this, you will have to answer two things first:

- Who will be part of the community-based monitoring team?
- How will you be able to get your operations going?



This part of the manual will help you answer these questions. It will first lay down the natural members of the team and how you will be able to get the ball rolling to ensure that you and your team will have a successful monitoring initiative.

### MEMBERS OF THE MONITORING TEAM:

Before you start monitoring, you have to know who your monitors will be. When forming your monitoring team, one question will lead you to the most natural pool of stakeholders who could join you in your initiative: Who will be most affected / interested by the school building project?

The following stakeholders are laid down for you guidance:

- School head.** The school principal or the school head is probably the highest ranking official in the school community and thus is pivotal in the monitoring initiative. The direction and vision of the school is usually put in his/her hands. He/ She is most accountable in ensuring the development of his/ her school and is highly interested in the prospect of new classrooms.
- Teachers.** The teachers are probably one of the most affected members of the school given that having a good classroom will make it easier for them to teach well. With fewer students in an enclosed classroom, they wouldn't have to strain their lungs just to get themselves heard by the class.
- Boy Scout and Girl Scout Coordinator.** The Girl Scouts and Boy Scouts of the Philippines have always been active in monitoring government projects, from textbooks delivery to

school buildings construction. With their institutional vision to contribute to nation-building, they are naturally receptive to a community-based monitoring of school buildings.

- D. **Parents.** Parents can provide the drive to demand quality services from the government. With their children's education as their main motivation, they can claim representation of their children's needs in the monitoring initiative.
- E. **Students.** The students are of course the main stakeholder; they are the main beneficiaries of the classroom. In high schools particularly, students are encouraged to monitor their future classrooms. This can even be an activity for the boy scouts and girl scouts of the school.
- F. **Local NGOs.** Representatives from local NGOs can also be invited to join the team. NGOs are usually service-oriented and are able to provide a civil society framework for the team.
- G. **Project Engineer.** The project engineer, either from the Department of Education or from the Department of Public Works and Highways depending on the implementing agency is already conducting monitoring of the project. The community-based monitoring can complement their work as the team can monitor when the project engineer is not present.

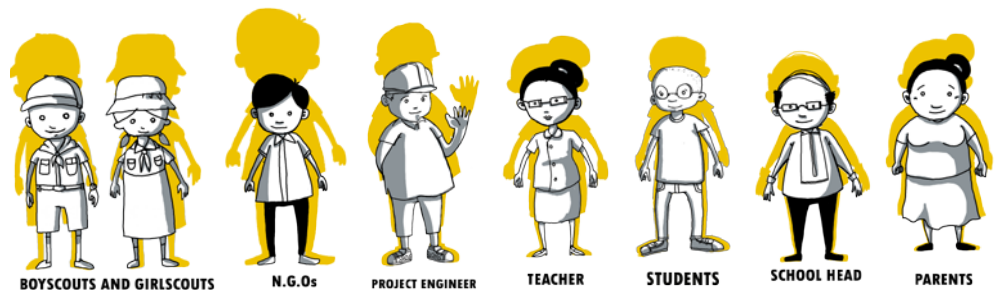

Of course, the abovementioned people are only the minimum members of your team. You may invite from your local government and from other sectors in your school community who may be interested in volunteering their time for the school improvement.

## SETTING UP A COORDINATION AND COMMUNICATION SYSTEM

Before you start you monitoring, it is important to set-up a coordination and communication mechanism. Coordination set-up is necessary in a multi-stakeholder monitoring project because it provides an instrument that enables your monitoring team to link with other actors and institutions that you can work together with to accomplish a certain goal. Crucial to establishing linkages is your

mechanism for communication that will facilitate coordination of actions, decision-making and sharing of information.

Coordination and reporting are critical elements of your monitoring project. At the heart of coordination and reporting is communication.

## SETTING UP A COORDINATION AND COMMUNICATION SYSTEM

The success of your monitoring project greatly depends on how well you are able to establish partnerships with different stakeholders. This entails, of course, an effective communication and coordination strategy, to get hold of their cooperation and support. Coordination set-up is necessary in a multi-stakeholder monitoring project because it provides an instrument that enables your monitoring team to link with other actors and institutions that you can work together with to accomplish a certain goal.

In Bayanhang Eskwela, you will find internal and external coordination as the usual set-up.

Coordination and reporting are critical elements of your monitoring project. At the heart of coordination and reporting is communication.

So how do you communicate effectively? Just four things according to Idealliance.org ...

1. Be careful when giving information as this may lead to inaccurate perception.
2. Understand the values, perceptions and behavior of the people you interact and communicate with.
3. Avoid misunderstanding brought about by poor communication or miscommunication.
4. Clarity, logic and coherence should always be your best friends.

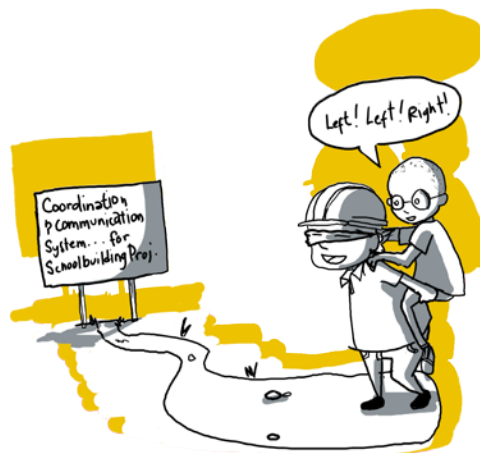

**COORDINATION**

### Internal Coordination

Internal communication refers to the coordination of the team members. Make sure to keep a database of all your members and exchange cellphone numbers so you can text each other especially for urgent matters.

The functions of the team members must also be defined and their tasks must be strategically delegated. The division of labor, though be careful not to make it rigid, should be put in place to ensure the proper functioning and coordination of the team.

Remember to ask yourself when distributing tasks and functions: who should perform what? You may set criteria as you wish, but you should be guided by the idea that every job comes with great responsibility and a sense of accountability.

### External Coordination: Channels of Communication

Before you begin anything, you should already have a clear plan on how to coordinate to make your monitoring project running! This means you should know who to contact outside of your team when certain issues are raised.

Coordination in an oversight monitoring is not complicated as it only involves a team consisting of representatives from different agencies and organizations that coordinate with each other, to do a monitoring project and come up with a report.

The figure below shows the coordination set-up in Bayanihang Eskwela. In Bayanihang Eskwela, G-Watch collaborated with the Department of Public Works and Highways (DPWH), Department of Education (DEPED), and the Office of the Ombudsman (OMB).

If you go through them and observe, this coordination set-up of community-based monitoring shows you that civil society counterparts create parallel national to local coordination set-up which mirrors the structure of the government.

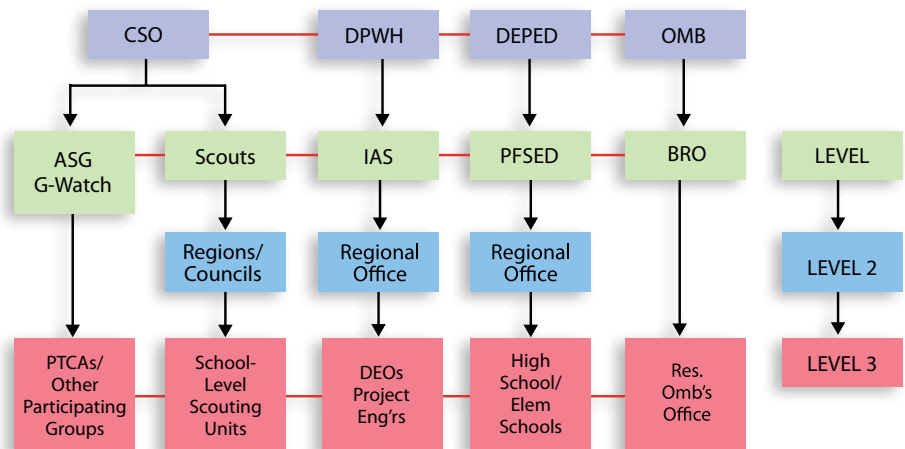

Coordination Structure of Bayanihang Eskwela

In the diagram above, the team representing different agencies may contact their regional or national level agencies to send communication, reports and thus raise important issues which may come up in the monitoring process.

As you may have observed, coordinating at the national level is like a matter of passing through organizational channels. With

the nationwide stretch, you are able to coordinate with the government at different levels down to the farthest communities. For instance, the organized nationwide presence of the Scouts group in the Bayanihang Eskwela demonstrates coordination from national level down to the regional, provincial (Council), district and school levels.

Noticeably, national level coordination slides down to the local and community levels. The community level requires some more coordination and you should also have a clear coordination plan or set-up.

Now the internal coordination and the external coordination should not be taken separate from each other as they will be important once the monitoring is on-going as seen in the diagram below:

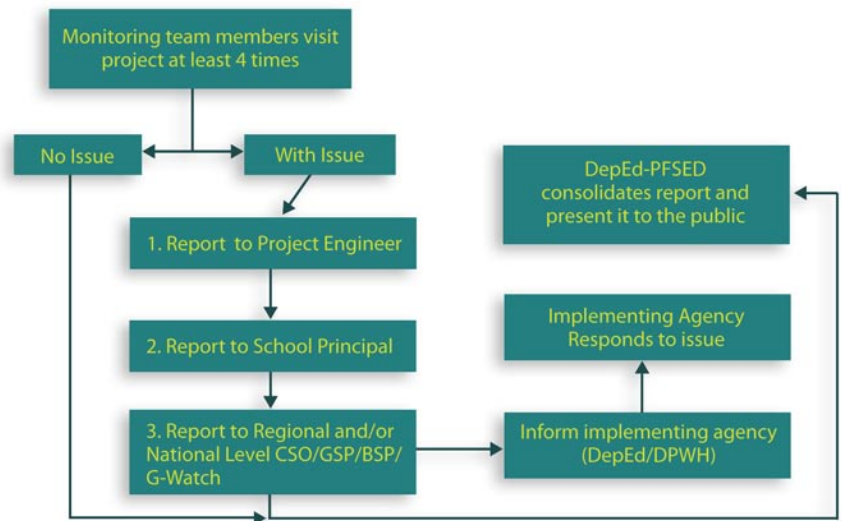

Monitoring Coordination Plan of *Bayanihang Eskwela*

## Capacity Building of Community-based SBP Monitoring Teams

In building the capacity of your team, a simple briefing-orientation would be the most convenient way of sharing basic information and skills required to enable a community or group of volunteers to conduct a monitoring. Bayanihang Eskwela however also promotes on-the-job training as part of the capacity-building component of the project. Thus the first monitoring stint of the team (and even every initiative after that) will serve to build the capacity of the members.

### BRIEFING ORIENTATIONS!

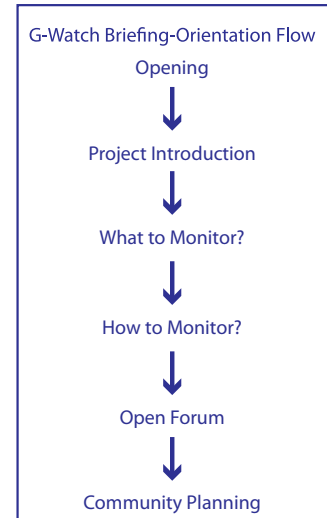

Since briefing-orientation serves as a venue to inform monitors of what they will monitor and how they will conduct the monitoring, all materials needed for the actual monitoring should already be prepared, most importantly the monitoring tool and report forms. It is also very crucial to know who to invite and how to ensure their attendance.

What are the basic objectives of briefing-orientation:

- o to gather the target participants in the monitoring project;
- o to introduce the project to the target participants;
- o to brief the target participants on what the project intends to monitor;
- o to orient the target participants on the Bayanihang Eskwela Checklist and the reporting mechanism to be used; and
- o to provide a venue for the target participants to meet and plan for their monitoring activities.

To achieve this, the briefing orientation shall be divided into three parts: (1) Introduction to G-Watch and Bayanihang Eskwela, (2) how to use the Bayanihang Eskwela Checklist in school building monitoring, (3) Construction Monitoring Tips and (4) planning workshop.

## ***Component 1: Introduction to Bayanihang Eskwela***

This part will serve as an introduction that shall brief the members of the team on what Bayanihang Eskwela is, and why it is important to monitor school buildings.

The objective of this part is to highlight the following:

- » The importance of **citizen participation in governance and monitoring of government services**.
- » The benefits of **constructive engagement** and collaboration with government.
- » The **right of every child to quality school building** for better education and the citizen's role in checking proper school building implementation.

SOURCE OF DISCUSSION: Bayanihang Eskwela Manual Introduction

RESOURCE PERSON YOU COULD INVITE: Local NGOs monitoring government school building or the G-Watch Team

You can ask your members to expound on the themes above. You can use metacards where they can write their opinion which they could later on share with the group.

## ***Component 2: Bayanihang Eskwela Checklist Training:***

For the next part, the team shall orient themselves on how to use the Bayanihang Eskwela Checklist which you can find in Annex 1 of this manual. This checklist shall guide you on each stages of school building construction.

The objectives of this part thus is:

- » Allow the team enough time to learn how to use the checklist together
- » Clarify areas on the checklist that need clarification

Don't worry, the checklist is very easy to accomplish. All you have to do is answer 'yes' or 'no'. Try accomplishing one checklist so you get a feel on how it should be answered.

Components of SBP implementation you should monitor:

1. School Profile
2. Pre-Construction Stage
3. Construction Stage
4. Post-Construction Stage
5. Conduciveness of SBP to Learning
6. Responsiveness of SBP to School Need

SOURCE OF DISCUSSION: Bayanihang Eskwela Manual Part D: Monitoring Using The Bayanihang Eskwela Checklist and Annex 1

RESOURCE PERSON YOU COULD INVITE: Division Physical Facilities Coordinator or G-Watch Team

### ***Component 3: Construction Monitoring Tips***

After learning how to use the checklist, the team shall invite their Physical Facilities Coordinator or a local engineer and ask for tips on what to look out for in monitoring school buildings to further deepen their capacity in monitoring school building.

The team should also research on DepEd standards which they can easily access online (the internet) or from their local divisions.

The objectives of this part are:

- » To familiarize the team on standards in school building monitoring
- » To orient the team on the red flags they should look out for

SOURCE OF DISCUSSION: Bayanihang Eskwela Manual Annex 2

PFSED Website: <http://deped-pfsed.wikispaces.com/Building+designs>

RESOURCE PERSON YOU COULD INVITE: Division Physical Facilities Coordinator or local engineers

### ***Component 4: Planning Workshop***

The planning workshop shall be done after the team has been trained on how to use the Checklist and the monitoring points that need to be considered.

Its main objectives are:

- » To provide an opportunity for the Community-Based SBP Monitoring Team to be acquainted and have a leveling-off of expectations.
- » To prepare an action plan for effective and efficient performance of tasks and delivery of outputs.

To accomplish this, you must be able to identify the necessary activities the team must undergo and to plan contingency plans or strategies for challenges you may foresee. Below are guide questions you can follow:

1. What are the specific activities the group must undertake to perform tasks or deliver expected outputs?
2. What difficulties/challenges might the group encounter?
3. What strategies will the group employ to address the difficulties/challenges?

In making the team’s plan, below is a template you can use to answer the questions above. This can serve as the team’s guide or “to do” list.

Tasks	Specific Activities				Possible Challenges/ Difficulties	Strategies to Address Difficulties
	Activity	Time Frame	Person in Charge	Resources Needed		
Organize						
Build Capacity						
Monitor						
Report						

## LEARNING BY DOING!

You should also know that a large part of building capacity of monitors is actually conducting the monitoring. Actual experience will build both your skills in monitoring, as well as your knowledge on practical implications and manifestations of abuses as well as of good performance in school building construction.

Some activities you might want to explore to deepen your competency in monitoring are the following:

1. *Mentoring.* You may want to find someone you trust who knows much about school building construction to mentor you as you go through the monitoring. It could be the Physical Facilities Coordinator, project engineer, or any local engineer or architect you may ask to walk you through the different processes and aspects of the school building project as you monitor.
2. *Role-playing.* You can never underestimate the power of role-playing. You may think it’s only for students, but it can help you visualize how your own monitoring activity will look like. You can even think about scenarios you might encounter and thus prepare for contingency plans when challenged arise.
3. *Field Trips.* Field trips to other areas where similar initiatives are existing may serve as a learning experience, so that your team can learn from the practices of other groups.

Can you think of other ways that would make you a better monitor? Go explore innovative activities that you can incorporate in the Bayanihang Eskwela initiative.

## Monitoring Using the Bayanihang Eskwela Checklist

Now, you must be wondering, how an ordinary citizens could monitor school building projects even without formal education in engineering. This section will show you how.

The **Bayanihang Eskwela Checklist** for the monitoring of school building construction projects is an easy-to-use guide for ordinary, non-technical people which they can bring during the actual monitoring visits to the project site. This will aid you and your monitors in inspecting the implementation of the school building project.

### Reminder:

- On-site inspection provides real-time information on the progress of project implementation
- **Take pictures! And take down notes!** Photo-documentation provides clear evidence of project outputs

### Don't forget to bring the following:

#### *G-Watch Checklist*

- Copy of the Program of Works
- Notebook and pen
- Camera
- Tape Measure

## FORMAT

The checklist has four columns. The first column contains the "Monitoring Points", which are in question-form answerable by "yes" or "no". The monitor simply checks the second or third columns, which are the "Yes" or "No" columns, respectively, to answer the questions. The fourth column asks for "Details" of the answer. Some details are pre-determined in boxes that have to be checked if they have been fulfilled while others ask for date, place and measure of area or observations and elaboration.

## MONITORING STAGES

The Bayanihang Eskwela Checklist covers six (6) major sections which corresponds to six important aspects and stages of the school building project which you would want to monitor, namely:

- (1) School profile
- (2) Pre-construction stage
- (3) Construction stage
- (4) Post-construction stages
- (5) Conduciveness to learning
- (6) Responsiveness to school need

Let us discuss each stage one by one to give you and your monitors ample understanding on how to use the checklist. Let

us see the accomplished Bayanihang Eskwela checklist of Petrang Elementary School:

## SCHOOL PROFILE

At the first section of the checklist, you are going to be asked to indicate the general information about the school and the profile of the monitor answering the checklist:

Name of School:	<u>Petrang Elementary School</u>	Name of Monitor:	<u>James Labergas</u>
Location:	<u>Malabon City</u>		
District:	<u>2nd District</u>		
Division:	<u>Malabon Division</u>	Organization:	<u>Boy Scouts Coordinator</u>
Project:	<u>2 Classroom School Building</u>		
Contractor:	<u>United Colors Contracting Company</u>		
Planned Duration:	<u>120 days</u>	Sex:	<u>M</u>
Planned Cost:	<u>P 1, 200,000 M</u>	Age:	<u>34</u>

The answer to this part will be seen from the Program of Works. This will spell out how long the construction should be, and the cost of the school building to the monitored.

Afterwards, you will be asked to answer general data about the school. The school profile gives you a bird's eye view of the condition and needs of the school. It covers the general indicators that reflect what other material necessities the school is lacking. In the sample example below, what seems to be the most important need of the school that need to be addressed?

1:33 means there is 1 teacher for every 33 pupils. You get this number by dividing the total number of students over the total number of teachers in a school. This is considered generous. The healthy number of students per teacher is less than 45. A number above this means there is already shortage if teachers.

The ideal textbook ratio is 1 student is to 1 textbook. Thus, it is evident that there is shortage in English textbooks as four pupils share in 1 textbook.

Of course, it is ideal that all students each have their own seat. Anything above 1:1 is thus undesirable.

For effective teaching, it is desirable that all classrooms have at least one blackboard. Fortunately, Petrang ES has 2 blackboards per classroom.

GENERAL SCHOOL NEEDS	
Student Population	520
Teacher-student Ratio	1:33
Textbook-student Ratio	
Math	1:1
Science	1:1
English	1:4
Filipino	1:1
Classroom-student Ratio	1:65
Seat-student Ratio	1:2
Classroom-blackboard Ratio	1:2

The student population is a good reference point to check whether your instructional materials, equipment and facilities are enough.

The ideal classroom ratio is 1:45 or lower than that following the color coding below

Student per classroom	Color	Status
Less than 46	BLUE	Ideal
46 - 50.99	YELLOW	Moderate Shortage
51 - 55.99	GOLD	Shortage even with double shifting
More than 56	RED	Acute shortage in Classroom
---	BLACK	No instructional room

Thus, Petrang ES is experiencing severe shortage in classroom.

As part of the School profile, you will also be asked to find some educational development indicators of your school which you may obtain from the school registrar. These include the following:

Educational Development Indicators	
School NAT Score	2007: 64 %
	2008: 72 %
	2009: 70 %
Completion Rate	2007: 94%
	2008: 92 %
	2009: 93 %
Dropout Rate	2007: 2 %
	2008: 3%
	2009: 4 %

- » *School National Achievement Test (NAT) Score* for the past three years. This will let you know if your school is performing well academically and whether it has improved in the last years. You may use this data to probe on the possible reasons for such performance.
- » *Completion Rate*. This gives you an idea on how much of the total enrollee are able to graduate and complete their studies on time. In Petrang ES, 7 % of the graduating batch was not able to get passing marks and will have to repeat next year.
- » *Dropout Rate*. This is the percentage of students who leave school and drop out. The number of dropouts apparently increased in the example given above.

Educational development indicators are important for monitors to understand the present accomplishments or challenges the school are facing academically.

Now with this information at hand – the general school needs and the educational development indicators – the monitors have a reference point by which they can identify the probable reasons for the quality of their school’s educational performance and the possible remedies that can be pursued.

In the Petrang ES for instance, the school community attribute their low NAT to the shortage of classroom and seats. Students would have to cramp themselves inside their classroom and sometimes share in one seat.

## PRE-CONSTRUCTION

The next section of the checklist will now lead your focus to the school building project to be implemented.

Now, you must be excited to get your boots on and get down and monitor the construction. But hold your horses! There are still some stages you should monitor before the construction begins.

The pre-construction stage includes a number of activities that involves preparing and planning for the construction of the school building:

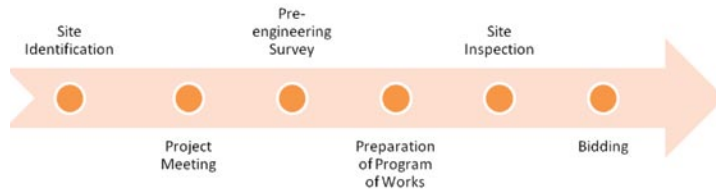

Figure 1: Pre-Construction Activities

### Activity 1: Site Identification

Site Identification is when the project implementers choose where in the school campus the building will be constructed. Herein, the checklist will ask you to answer the following questions:

Answer with a "Yes" or a "No" by putting a check on the column of your answer. You may indicate in the last column the details of your answer.

Monitoring Points	Yes	No	Details
<b>Activity 1: Site Identification</b>			
1. Did the issue of "property ownership" surface in the project site identification? <i>Lumitaw ba sa site identification ang usapin sa pagmamay-ari ng lupa?</i>		✓	Type of Property <input type="checkbox"/> public property <input type="checkbox"/> donated private property <input type="checkbox"/> expropriated private property
2. Was the site suitable for the project? <i>Angkop ba ang lugar sa proyekto?</i>	✓		<input type="checkbox"/> geographical concern <input type="checkbox"/> environmental concern <input type="checkbox"/> social concern <input type="checkbox"/> other concerns
3. Was there a meeting to discuss issues and concerns? <i>Nagkaroon ba ng pulong upang pag-usapan ang mga isyu?</i>	✓		When: Where: Represented offices/groups: <input type="checkbox"/> DPWH <input type="checkbox"/> DepED <input type="checkbox"/> LGU <input checked="" type="checkbox"/> Barangay Office <input checked="" type="checkbox"/> PTCA <input checked="" type="checkbox"/> DENR <input checked="" type="checkbox"/> NGO

Make sure to indicate if all people important in the meeting were invited.

## Activity 2: Project Meeting

The project meeting is conducted by the implementing office (DepEd/DPWH) and the school community to finalize the details of the project. Herein, a project management team shall be formed to oversee the implementation of the project.

Activity 2: Project Meeting			
Monitoring Points	Yes	No	Details
1. Was there a meeting to finalize project site? <i>Nagkaroon ba ng pulong upang pagdesisyunan ang project site?</i>	✓		When: Where: Represented offices/ groups: <input type="checkbox"/> DPWH <input checked="" type="checkbox"/> DepED <input type="checkbox"/> LGU <input type="checkbox"/> Barangay Office <input checked="" type="checkbox"/> PTCA <input checked="" type="checkbox"/> DENR <input checked="" type="checkbox"/> NGO
2. Was the project management team formed? <i>Binuo na ba ang project management team?</i>	✓		Name of Project Head: Raya Isnariyam
3. Was the documentation of property ownership in order? <i>Maayos ba ang dokumentasyon ng pagmamay-ari ng lupa?</i>	✓		Type of Documentation <input type="checkbox"/> Deed of Donation <input type="checkbox"/> Sale Document <input checked="" type="checkbox"/> Annotated Original / Transfer Certificate of Title

It is important that the documentation of property ownership of the lot where the building will be constructed is well-documented to prevent legal problems in the future. Try to get access to a copy.

## Activity 3: Pre-Engineering Survey

The Pre-Engineering Survey is conducted to assess whether the lot is suitable for the building to be constructed in terms of size and quality.

Activity 3: Pre-Engineering Survey			
1. Was a pre-engineering survey conducted? <i>Nagsagawa ba ng pre-engineering survey?</i>	✓		When: July 1, 2010  Lead in the survey: Project Engineer  Observations: The site is enough, but soil needs to be tested.
2. Did the survey confirm that the building to be constructed fit the land area? <i>Nakumpirma ba ng survey na kasya ang itatayong gusali sa napiling lugar?</i>	✓		Area needed: 9x9 sq. m.  Area available: 10x9 sq. M

## Activity 4: Preparation of Works (POW)

The Program of Works is the most critical document in your monitoring. The Program of Works contain the components of the school building to be constructed and the materials to be used. It specifies the amount and the type of supplies that the contractor should provide. Thus, make sure you get a copy! (Don't worry, it is open to the public and the school is mandated to have a copy.)

If you are not given a POW, this should raise a red flag to the team.

### Activity 4: Preparation of the Program of Works

	Yes	No	
1. Were you given a copy of the Program of Works? <i>Binigyan ka ba ng kopya ng Program of Works?</i>	✓		Cost: 1,200,000 Duration: 120 days
2. Did you have difficulty getting a copy of the Program of Works? <i>Nahirapan ka bang himingi ng kopya ng Program of Works?</i>	✓		Elaborate: The DPWH Project Engineer was not available when we went there to pick up the POW.
3. Is the Program of Works consistent with DepED standards?? <i>Ang Program of Works ba ay naaayon sa itinakdang pamantayan ng DepED?</i>	✓		DepED standards: <input checked="" type="checkbox"/> cemented floor <input checked="" type="checkbox"/> smooth finished walls <input checked="" type="checkbox"/> painted walls, ceiling and roofing <input checked="" type="checkbox"/> full cathedral-type ceiling (for single-storey) or drop ceiling (for multi-storey) <input checked="" type="checkbox"/> complete set of windows (2 facing walls) <input checked="" type="checkbox"/> two entrances with doors <input checked="" type="checkbox"/> complete electrical wires and fixtures <input checked="" type="checkbox"/> roofing or weather protection <input checked="" type="checkbox"/> blackboard

The Department of Education has made standard designs of school buildings. You may refer to Annex 2 for the standards.

## Activity 5: Site Inspection

The Site Inspection is done after the plans have been finalized. This serves to validate whether the plan will be appropriate for the site.

Activity 5: Site Inspection		
1. Was a site inspection conducted?  <i>Nagsagawa ba ng site inspection?</i>	✓	When: July 15, 2010 Where: Rear part of the campus
2. Did DPWH/DepEd give orientation on project plans during site inspection?  <i>Nagsagawa ba ng project orientation?</i>	✓	When: July 15, 2010  We found the orientation a bit confusing.
3. Was the information given in the orientation consistent with the Program of Works?  <i>Ang impormasyon bang ibinigay sa orientation ay naaayon sa nakasaad sa Program of Works?</i>	✓	Inconsistencies (if any):  Represented offices/groups:  <input checked="" type="checkbox"/> DPWH <input checked="" type="checkbox"/> DepEd <input checked="" type="checkbox"/> LGU <input type="checkbox"/> Barangay Office <input type="checkbox"/> PTCA <input type="checkbox"/> DENR <input type="checkbox"/> NGO

The project implementer either from DepEd or DPWH should orient you about their plans. Check if what they told you is consistent with the POW.

## Activity 6: Bidding

Now the bidding is probably the most critical activity in the pre-construction stage of the SBP implementation. Herein, the contractor who will construct the building will be chosen through a bidding process to ensure that the government will get the cheapest price for the service. The checklist will help you in checking if bidding followed due process.

### RED FLAGS:

Make sure you are able to participate and observe the pre-bid conference, bid opening and post-qualification. Guard against the following:

- Overpricing of unit prices
- Tailor fitting in item specifications
- Inclusion of unnecessary items in the project
- Collusion of bidders
- Favoring of one bidder
- Acceptance of late bids
- Acceptance of incomplete submissions

### Activity 6: Bidding

<p>1. Was bidding conducted for the project?</p> <p><i>Nagsagawa ba ng bidding para sa proyekto?</i></p>	<p>✓</p>	<p>If yes, When: July 23 Where: DPWH District Engineering Office Who presided: BAC Chair</p> <p>If no, Mode of procurement used:</p> <p>Amount of Contract: 102,202.31</p> <p>Name of Contractor: United Colors Construction Company</p>
<p>2. Were there issues and concerns raised?</p> <p><i>May mga usapin bang tinalakay?</i></p>		<p>Elaborate:</p>
<p>3. Was post-qualification conducted?</p> <p><i>Nagsagawa ba ng post-qualification?</i></p>	<p>✓</p>	<p>Lowest Calculated Responsive Bids: 1. 102,202.31 2. 109,221.5 3. 115,401.2</p>
<p>4. Did you do your own checking of contractor's capacity?</p> <p><i>Nagsagawa ka ba ng sariling pagsisiyasat sa kapasidad ng contractor?</i></p>	<p>✓</p>	<p>Findings: The documents we got from the DPWH showed the capacity of the contractor.</p>
<p>5. Was the Notice to Award sent to the winning bidder?</p> <p><i>Naipadala ba ang Notice of Award sa nanalong bidder?</i></p>	<p>✓</p>	<p>When: August 3, 2010</p>
<p>6. Did the winning bidder send Letter of Acceptance?</p> <p><i>Nagbigay ba ng Letter of Acceptance ang nanalong bidder?</i></p>	<p>✓</p>	<p>When: August 5, 2010</p>
<p>7. Was the Notice to Proceed sent to the winning bidder?</p> <p><i>Naipadala ba ang Notice to Proceed sa nanalong bidder?</i></p>	<p>✓</p>	<p>When: August 8, 2010</p>

## CONSTRUCTION STAGE

Now put your gears on because this part of the checklist will ask you to get down and dirty! It's time to go to the construction site and monitor if the school building construction is being done according to quality standards.

The construction of course will probably take some time, but week after week, it should be more and more like a school classroom or building, from the posts to the walls, and finally to the finishing touches.

Now, the construction phase generally follows the process below:

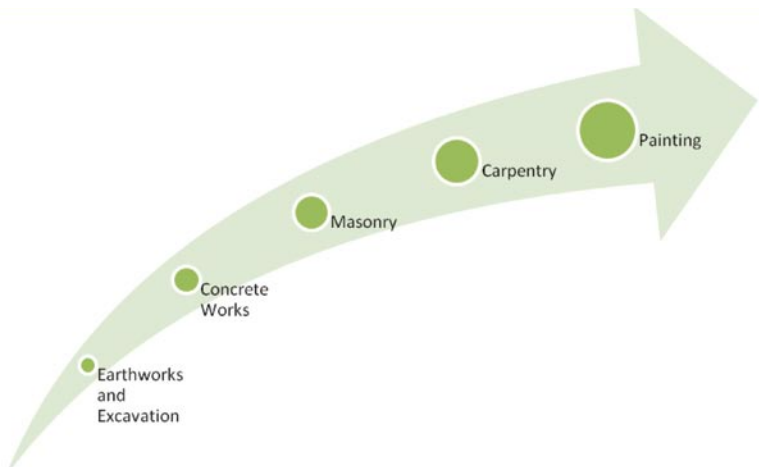

Figure 2: Different Stages in the Construction Process

Let us now look at how to monitor each stages of the construction process more closely.

### ***Activity 1: Earthworks and Excavation***

Earthworks and excavation deal with the moving of massive quantities of rock. This refers to the clearing of the site as well as the digging of the ground where the foundations of the building will be installed.

It is important to take note if the excavation caused any unnecessary disturbance to the environment. These questions you may answer by simply observing the excavation and the clean up afterwards.

Activity 1: Earthworks and Excavation

	Yes	No	
<p>1. Were garbage, plants, remains of old structures, and other obstructions removed and disposed of properly?</p> <p><i>Maayos bang tinanggal at itinapon ang mga basura, halaman, tira ng lumang istruktura at iba pang sagabal sa konstruksyon?</i></p>	✓		Observations:
<p>2. Were there items (e.g. structures, trees) that had been unnecessarily damaged?</p> <p><i>Mayroon bang bagay, istruktura o puno na aksidenteng nasira?</i></p>		✓	What: Who is responsible for the damage?
<p>3. Was the excavation area in accordance with the plan in the Program of Works?</p> <p><i>Ang sukat ba ng excavation ay ayon sa plano sa Program of Works?</i></p>	✓		Planned Area in Program of Works: Actual Excavated Area:
<p>4. Did the excavation disturb any slopes?</p> <p><i>May nasira bang talilis dahil sa paghuhukay?</i></p>		✓	Observations:
<p>5. Was the excavated surface smooth and uniform?</p> <p><i>Patag at pantay ba ang ibabaw ng hukay?</i></p>	✓		Observations:
<p>6. Were the excavated materials disposed of properly?</p> <p><i>Itinapon ba nang maayos ang mga nahukay?</i></p>	✓		Observations:
<p>7. Were the excess materials (e.g. rocks and boulders) used as backfill materials?</p> <p><i>Ginamit bang backfill materials ang mga bato?</i></p>		✓	If yes, was there permission from the Project Engineer?

As you may have observed by now, the checklist will refer you to the POW, so make sure you have it with you at all times!

Activity 2: Concrete Works

	Yes	No							
1. Was Type A or Portland Cement used? <i>Type A o Portland Cement ba ang ginamit?</i>	✓		The cement bags indicated it was Portland cement.						
2. Were the bags of cement stored properly? <i>Nakaimbak ba nang maayos ang mga bag ng semento</i>	✓		Indicators: <input type="checkbox"/> Bags of cement may get wet in the storage room <input type="checkbox"/> Storage room has cracks or openings between walls and roofs <input type="checkbox"/> Flooring is above ground <input type="checkbox"/> Cement bags are stacked close together  Observations:						
3. Were cements that already solidified or which contain lumps of caked cement still being used? <i>Ginagamit pa rin ba ang mga sementong namuo-muo at nagkatipak-tipak na?</i>		✓	Observations:						
4. Were cements salvaged from discarded or used bags still being used? <i>Ginagamit pa rin ba ang mga tira-tirang semento?</i>		✓	Observations:						
5. Did they mix cement with clean water? <i>Malinis na tubig ba ang hinahalo sa semento?</i>	✓		Indicators: <input checked="" type="checkbox"/> no oil / no slat / no acid / no álcali / no grass  Observations:						
6. Were quality coarse aggregates (gravel) used? <i>Tamang kalidad ba ang ginagamit na graba?</i>	✓		Indicators: <input checked="" type="checkbox"/> Color is blue, not brown / Clean, no mixture of soil or clay / Hard, strong and durable; do not break easily / Free from any adherent coatings or crystals  Observations:						
7. Were quality fine aggregates (sands) used? <i>Tamang kalidad ba ang ginagamit na buhangin?</i>	✓		Indicators: <input checked="" type="checkbox"/> Must come from the river, not sea (color: black) / Sands from different sources are not combined together  Observations:						
8. Was the correct proportion of water, cement and aggregates followed in the construction of columns and beams? <i>Sinusunod ba ang tamang panumbasan sa paghahalo ng tubig, semento at aggregates?</i>	✓		Indicators: <input checked="" type="checkbox"/> Water: 15%-20% / Cement: 7%-14% / Aggregates: 66%-78%  Observations:						
9. Were the materials in good shape? <i>Nasa maayos na kondisyon ba ang mga materyales?</i>	✓		Indicators: <input checked="" type="checkbox"/> no rust / no cracks and laminations / no surface irregularities or mill scale  Observations:						
9. Were the type, size and quantity of materials in accordance with the Program of Works? <i>Ayon ba sa Program of Works ang uri, sukat at bilang ng materyales?</i>	✓		<table border="1"> <thead> <tr> <th>Type</th> <th>Size</th> <th>Qty</th> </tr> </thead> <tbody> <tr> <td>Cement Portland cement</td> <td>25 kg bags</td> <td>100 bags</td> </tr> </tbody> </table>	Type	Size	Qty	Cement Portland cement	25 kg bags	100 bags
Type	Size	Qty							
Cement Portland cement	25 kg bags	100 bags							
9. Were the materials stored properly? <i>Maayos ba ang pag-iimbak sa mga materyales?</i>	✓		Indicators: <input checked="" type="checkbox"/> Placed on a platform or above ground <input checked="" type="checkbox"/> It does not pose danger or injury to people  Observations:						

Cement or gravel when exposed to water may form lumps. You don't want this as the consistency of the concrete mixture will not be compromised.

Check the dimensions of structural components (column footing, columns & beams) to be concreted.

Make sure that the correct proportions of cement, sand and gravel are being used, it should be 1:2:4.

Indicators:  
 Water: 15%-20% / Cement: 7%-14% / Aggregates: 66%-78%

## Activity 2: Concrete Works

Concrete works refer to construction work dealing cement, sand, gravel and other coarse aggregates. Such works mainly involve mixing of materials to form concrete for walls, floorings, etc.

## Activity 3: Masonry

Masonry is the building of structures from units or building blocks with the use of mortar paste. This is usually when the workers would build the hollow blocks together with the use of a cement-like paste. In this stage, wires and steel bars are also installed in the structures for support and strength.

Mortar and plaster mixture shall be 1:2 or 1:3 cement and sand proportions.

Activity 3: Masonry		
1. Was the size of hollow blocks used in accordance with the Program of Works?  <i>Ayon ba sa Program of Works ang sukat ng hollow blocks?</i>	✓	Program of Works: 6" Actual: 6"  Observations: Blocks were ok!
2. Was the size of steel bars used in accordance with the Program of Works?  <i>Ayon ba sa Program of Works ang sukat ng steel bars?</i>	✓	Program of Works: • 12mm dia - .888 kg/m • 16mm dia -1.58 kg/m • Actual: • 12mm dia - .888 kg/m • 16mm dia -1.58 kg/m  Observations:
3. Was the size of wires used in accordance with the Program of Works?  <i>Ayon ba sa Program of Works ang sukat ng wires?</i>	✓	Program of Works: .124 wire diameter inches Actual: 124  Observations:

## Activity 4: Carpentry

Carpentry refers to the work done with timber and wood. This may include the installation of the ceiling, roof, doors, windows, etc.

Check all materials for the roofing and ceiling works,

Nailers and hangers should be 2x2 inches and spacing should be 2 ft. in both ways.

Ceiling boards should be clean and smooth, and joints should have a 6mm groove.

Activity 4: Carpentry		
1. Did the contractor buy and deliver the materials needed?  <i>Ang contractor ba ang bumili at naghatid ng mga materyales?</i>	✓	Observations: The materials had to be hauled twice. The city government helped them in transporting the materials
2. Did the contractor buy the right number, size, and shape of materials as stated in the Program of Works?  <i>Ayon ba sa Program of Works ang bilang, sukat at hug is ng mga biniling materyales?</i>	✓	Observations: The plywood for the ceiling were 3/4"
3. Were the timber materials in good condition?  <i>Ang mga kahoy ba ay nasa maayos na kondisyon?</i>	✓	Indicators: <input type="checkbox"/> no loose knots / no split / no worm hole / no decay / no warp / no ring separation
4. Were the materials stored properly?  <i>Maayos ba ang pagkaimbak ng mga materyales?</i>	✓	

## Activity 5: Painting

Of course, a classroom would look gloomy if it had no paint. With light colors, students would find it more enjoyable to study, and the classroom would feel wider and look brighter for the students.

Activity 5: Painting			
1. Was the paint of good quality?  <i>Maayos ba ang kalidad ng pintura?</i>	✓	Indicators: ✓ no excessive setting / no curdling / no caking / no gelling or thickening / no color separation / no lumps and skins	Observations:
2. Did the paint brush easily?  <i>Madali bang lumapat ang pintura?</i>	✓	Indicators: ✓ with good levelling properties / no running or sagging when applied to smooth vertical surface	Observations:

The Department of Education prescribes the following color which looks fresher and gives a cooler feel to the classroom:

ROOFING & ACC. DepEd Green	DOOR DepEd ODE Palmyra Green
COLUMNS DepEd Latex S/G Beige	COLUMNS DepEd S/G Enamel Beige
EXT. WALL DepEd Latex S/G Beige	EXT. WALL DepEd S/G Enamel Beige
INT. WALL DepEd Latex S/G Beige	INT. WALL DepEd S/G Enamel Beige
CEILING DepEd Latex Flat White	CEILING DepEd Flatwall Enamel

## POST-CONSTRUCTION STAGE

Voila! Before you know it, the school building will be finished and you're now quite proud that you witnessed it grow into full-fledged classrooms that your students can use.

Now, before they are put into use, you must first conduct a post-construction monitoring to check whether the finished product will live up the planned school building at the beginning of your monitoring.

The checklist guides you in monitoring two aspects of the finished school building: (1) the process and (2) the structure.

### The Process

The checklist will allow you to reflect back on the processes that the project has undergone. The assumption here of course is once due process is followed, the outcome is maximized in terms of cost, quality and time.

### The Structure

The second part enumerates the standard components of a complete school building. Now you only have to check whether the item is present or absent. As for the quality or peculiarities with the item, you may indicate it in the fourth column:

Access to information is right of every citizen, especially you as end-users of the school building.

If the construction is delayed, ask the contractor or DepEd/DPWH project engineers the reason behind the delays.

Monitoring Points			
	Yes	No	Details
<b>Process</b>			
Was the School Principal consulted on the Plans and Program of Works? <i>Kinunsulta ba ang School Principal sa plano at Program of Works?</i>	✓		The draft was already made and the principal was just given a copy.
Did DPWH District Engineering Office provide copy of Program of Works prior to construction? <i>Nagbigay ba ng kopya ng Program of Works bago magsimula ang konstruksyon?</i>	✓		
Was the schedule announced prior to construction? <i>Ipinaalam ba ang schedule bago magsimula ang konstruksyon?</i>	✓		When: August 5, 2010
Was construction completed within schedule? <i>Natapos ba ang konstruksyon ayon sa schedule?</i>	✓		Start: August 9 End: Dec 2, 2010
Was a joint Final Inspection conducted? <i>Nagsagawa ba ng joint Final Inspection?</i>	✓		When: August 9 Inspection Team members: <input type="checkbox"/> DPWH <input type="checkbox"/> DepED <input type="checkbox"/> Barangay <input type="checkbox"/> PTCA <input type="checkbox"/> CSO
Were defective works rectified within 15 days? <i>Naayos ba ang mga maling trabaho sa loob ng 15 araw?</i>	✓		Defects rectified: 1. Broken door hinge 2. Light: 1 bulb made into 2 bulbs 3.
Was construction completed according to specifications? <i>Natapos ba ang konstruksyon ayon sa mga takdang specifications?</i>	✓		Lacking: 1. 2. 3.

The (-) sign means the item is absent while the (+) sign means the item is present.

Monitoring Points	(-)	(+)	Comments / Observations
<b>Structure</b>			
Concreting			
Wall & Column Footings		✓	The walls had some hairline crack but construction men cement to hide the cracks.
Tie Beams/Beams		✓	
Floor Slab		✓	
Columns		✓	
Roofing & Accessories			
Trusses/Rafters		✓	
Purlins		✓	
Corrugated GI Sheet		✓	
Teckscrew		✓	
Doors and Windows			
Panel Doors		✓	Doors were made of good quality wood.
Flush Doors			
Steel Doors			
Steel Casement Windows		✓	Jalousie window in the 1st classroom were broken.
Jalousie Windows		✓	
Plumbing Works			
Pipes	✓		There were no pipes.
Fittings	✓		
Fixtures	✓		
Painting Works			
Roofings		✓	Ceiling had no paint
Interior & Exterior Walls		✓	
Ceiling	✓		
Doors & Windows		✓	
Electrical Fixtures			
Rough-ins		✓	
Wires		✓	
Fixtures		✓	
Bulbs/Fluorescents		✓	

## CONDUCTIVENESS TO LEARNING

Now your classroom may look beautiful but whether it is conducive for learning is quite another thing. Say you have a strong and sturdy school building but there were no safety features. Perhaps the classrooms were painted too dark that the classroom feels too gloomy and the students are not energized by the classroom.

It is important to take note of this to ensure that the building is properly constructed to achieve its purpose. This will also inform the Department of Education about possible modifications for their school building designs.

You don't want your classroom to be dark or humid. And you wouldn't want your classroom to be beside the school waste disposal facility. You definitely don't want a non-child friendly classroom. This part will allow you to grade how appropriate your classroom is for learning.

Monitoring Points	Yes	No	Comments / Observations
<b>Indicators</b>			
<u>Ventilation:</u> Are the classrooms well-ventilated? <i>Maaliwalas ba ang loob ng mga silid-aralan?</i>		✓	The air does not come in the room. The windows could be wider. We hope to buy new electric fans for the room
<u>Lighting:</u> Are the classrooms sufficiently lighted? <i>Sapat ba ang liwanag sa loob ng mga silid-aralan?</i>	✓		
<u>Space:</u> Are the classrooms spacious enough for the students? <i>Sapat ba ang lawak ng mga silid-aralan para sa mga estudyante?</i>	✓		
<u>Sanitation:</u> Was the school building site sanitary? <i>Malinis ba ang pinagtayuan ng mga silid-aralan?</i>		✓	What are the threats? Near by swamp that is may be inhabited by dengue mosquitoes
Is the school building free from health threats? <i>Ang mga silid-aralan ba ay walang banta sa kalusugan?</i>			How are they addressed? The DepEd contacted the DOH to conduct anti-dengue treatments in the school
<u>Safety:</u> Does the school building have safety features? <i>Mayroon bang safety features ang silid-aralan?</i>	✓		Inspection Team members: ✓ Emergency exit ✓ Security Grills ✓ Ramp
Were there safety risks in the construction of the SBP? <i>Nagkaroon ba ng mga banta sa kaligtasan noong itinatayo ang mga silid-aralan?</i>			
<u>Others:</u> What other aspects of the school building is either commendable or should still be improved? <i>Ano pang aspeto ng silid-aralan ang kapuri-puri o kaya naman ay dapat pa ipagbuti?</i>			Commendable: The classroom will really help us as our Grade 4 Section B has no permanent classroom. The classroom is well-built specially the windows which have extra security grills which is useful because sometimes burglars steal from the school. Still needs improvements: We hope there is also a comfort room. May be the doors should be made wider.

## RESPONSIVENESS TO SCHOOL NEED:

The checklist will also guide you in assessing whether the classroom building addresses the specific and peculiar needs of a school. Was it responsive to your particular need? Now if your school was located in an area where typhoon always hits, it will be disastrous to build a classroom made of wood!

Make sure the classroom built in your community is really what your school needs!

Do you really need a classroom? May be you need a library instead!

Or maybe you're in a coastal town and the paint to be used should prevent easy rusting of your roof?

Maybe your culture prescribes a more native design which your community would feel more at home with?

Monitoring Points	Yes	No	Comments / Observations
<p>Is the school under the Red and Black Category (Red – Equal to or more than 56 students per classroom; Black – No classroom available)?</p> <p><i>Nasa Red and Black Category ba ang eskwelahan, na nangangahulugang nasa 56 o higit pa ang estudyante kada silid-aralan o kaya ay walang silid-aralan sa eskwelahan?</i></p>	✓		<p>Number of Classrooms: 8            Number of Makeshift Classrooms: 2            Number of Condemnable Classrooms: 1            Number of Buildings: 3            Number of Condemnable Buildings: 1</p>
<p>Is the design of the classroom appropriate for the school environment?</p> <p><i>Naangkop ba ang disenyo ng silid-aralan sa kapaligiran ng eskwelahan?</i></p>	✓		<p>The area experiences lots of rains and flooding. The elevation of the building is just enough to prevent water from going inside.</p>
<p>Is the design of the classroom appropriate for the community's culture?</p> <p><i>Naangkop ba ang disenyo ng silid-aralan sa kultura ng komunidad?</i></p>	✓		<p>The standard building design of DepEd is acceptable to different indigenous communities in our school.</p>

### Immediate Concerns of the School

At the very end of the checklist, you will find a box that will ask you what the immediate concerns of your school are. This will serve as your opportunity to communicate to the Department of Education what you believe to be the most important need of the school that you wish the government could address.

#### Others:

What are the school's immediate concerns?  
 Ano pa ang ibang mahalagang pangangailangan ng eskwelahan?

We have a shortage of English textbooks.

## Processing Your Checklist and Generating Results

You have now finished monitoring the school building. Now what?

First, you have to collect all checklists accomplished by your monitoring team. The checklists however are still raw data that need to be consolidated. After collecting them, the challenge now is to make sense of the data and finally answer: Was the school building constructed efficiently in terms of cost, time, quality, quantity and process?

	Planned/ Normative	Actual	Variance	Cause of Variance	G-Watch Assessment	Agency Assessment
Time						
Cost						
Quantity						
Quality						
Process						

Now when you have collected the data, you have to aggregate and count the answers of the checklist as you would do a survey. You can use the Consolidated Data Template to be found in Annex 3 for this part. Let us try to go down some items in the template and illustrate how you can interpret the answers of your monitors:

### SCHOOL PROFILE

For the General School needs, assess whether the school experiences a shortage, sufficiency or surplus of the item indicated in the left most column.

GENERAL SCHOOL NEEDS	Standard/ Ideal Number	Actual School Data	Observation (Shortage, Sufficient, Surplus)
Student Population	--	520	
Teacher-student Ratio	1:35	1:33	Sufficient
Textbook-student Ratio			
Math	1:1	1:1	Sufficient
Science	1:1	1:1	Sufficient
English	1:1	1:4	Shortage
Filipino	1:1	1:1	Sufficient
Classroom-student Ratio	1:45	1:67	Shortage
Seat-student Ratio	1:1	1:2	Shortage
Classroom-blackboard Ratio	1:1	1:2	Shortage

In assessing the Educational Development indicators, you must assess whether your school has a good track record in absolute terms (whether it is above average or below) and in relative terms (whether it has improved or not over time) as seen below:

Educational Development Indicators	Ideal Number	Actual School Data	Observation	Improving, Stagnant, or Declining
School NAT Score	75 % (Passing Grade)	2007: 64 % 2008: 72 % 2009: 70 %	Below passing grade	Stagnant
Completion Rate	National Average  2007: 71.72% 2008: 71.72% 2009: 73.28%	2007: 94% 2008: 92 % 2009: 88 %	Above average	Declining
Dropout Rate	National Average  2007:6.37% 2008: 5.99% 2009: 6.02%	2007: 5 % 2008: 4% 2009: 2 %	Below Average	Improving

## PRE-CONSTRUCTION, CONSTRUCTION AND POST CONSTRUCTION STAGE

For the pre construction stage, you must count the number of Yes's and No's for each item. After which, you will assess whether there were deviations from standards that occurred.

Below you will find all the questions. The 2nd and 3rd columns will give you space where you can input the number of checks per item according to the checklist.

Monitoring Points	# of Yes	# of No	Explanation of Deviation
<b>Activity 1: Site Identification</b>			
1. Did the issue of "property ownership" surface in the project site identification?	0	5	
2. Was the site suitable for the project?	1	4	One observed that during rainy season, the site usually gets flooded.
3. Was there a meeting to discuss issues and	5	0	

There may be instances when a monitor will digress from the opinion of the team, perhaps due to difference in opinion, or because he was able to observe something the others were not.

If there is a deviation, indicate the reason in the last column.

The figure above is will serve as your guide in answering the succeeding items. This shall also be done for the construction and Post-construction stage - Process box as seen below:

Oftentimes, the reason for deviations may acceptable. This is why it is important to check with the stakeholders why a particular process was not followed.

Monitoring Points	# of Yes	# of No	Details
<b>Process</b>			
Was the School Principal consulted on the Plans and Program of Works?	0	5	The principal was sick at the time the plan was finalized
Did DPWH District Engineering Office/ DepEd Division Office provide copy of Program of Works prior to construction?	5	0	
Was construction completed within schedule?	0	5	There was typhoon last month.
Was a joint Final Inspection conducted?	5	0	
Were defective works rectified within 15 days?	4	0	
Was construction completed according to specifications?	5	0	

For the Post Construction – Monitoring Points, indicate whether the building has the item or not by checking the column that corresponds your answer: (-) for not present, (+) for present. Here you do not have to tally as this should be verifiable by simply observing the classroom and there is little room for subjectivity. It is however more important to aggregate the comments in the last column, where you should identify whether you assess the item to be generally good, average, or generally bad.

Monitoring Points	(-)	(+)	Quality (Good/Average/Bad)
<b>Structure</b>			
Concreting			Good
Wall & Column		✓	
Footings		✓	
Tie Beams/Beams		✓	
Floor Slab		✓	
Columns		✓	
Roofing & Accessories			Good
Trusses/Rafters		✓	
Purlins		✓	
Corrugated GI Sheet		✓	
Teckscrew		✓	
Doors and Windows			Average
Panel Doors		✓	
Flush Doors	✓		
Steel Doors	✓		
Steel Casement		✓	Windows are Easily
Windows		✓	broken
Jalousie Windows		✓	
Plumbing Works			There are no plumbing works
Pipes	✓		
Fittings	✓		
Fixtures	✓		
Painting Works			Bad
Roofings		✓	Thin application of
Interior & Exterior		✓	paint in the roofings
Walls	✓		
Ceiling		✓	There are no ceilings
Electrical Fixtures			Good
Rough-ins		✓	
Wires		✓	
Fixtures		✓	
Bulbs/Fluorescents		✓	

Sometimes, an item or two are sacrificed if there are not enough funds for the project. Just make sure that this is part of the POW or if not, make sure that there is a deviation order.

Your school building should have a warranty period. You should ask the contractor if they can fix broken items in the building.

## CONDUCTIVENESS TO LEARNING AND RESPONSIVENESS TO SCHOOL NEED

As in the items above, count the number of checks in the 'yes' column and in the 'no' column. In the last column, indicate the reason given by the team in their checklist.

Monitoring Points	# of Yes	# of No	Observations
<b>Indicators</b>			
Ventilation:	5	0	
Lighting:	3	2	The paint is thin and it makes the classroom look darker.
Sanitation:	5	0	
Safety:	0	5	There are no emergency exits
Others:	<p>Commendable:</p> <p>The DPWH project engineers are very open with their processes. They gave us sufficient information.</p> <p>The contractor responded to reports that some of the waste materials were not disposed of properly.</p> <p>Needs improvement: There should be more safety features.</p>		

Try not to report only the negative findings that you have found. As much as possible, ensure that you take note of the positive points as well. Enumerate them in the box provided in this section.

Monitoring Points	Yes	No	Comments / Observations
Is the school under the Red and Black Category	5	0	
Is the design of the classroom appropriate for the school environment?	5	0	
Is the design of the classroom appropriate for the community's culture?	3	2	The community prefers buildings made of metal because arson is rampant in the area. Nonetheless, it is welcomed by the community.

Process the Responsiveness to School Need similarly. Answer this with discernment as it is important to be sensitive to the peculiar conditions of the school. The design of the building should

thus be able to respect the particular culture and adapt to the environmental concerns of the community, as discussed in Part D.

Also take note if your school really needs a classroom. If you think you don't, try to inquire why it was given to you in the first place. Why was it not given to another school who really needs it?

Lastly, aggregate the concerns enumerated by your monitors. Try to highlight common concerns that were raised as this is indicative of what your team perceives is the most important service that your school needs.

## MAKING SENSE OF YOUR DATA

After you have consolidated all the checklists, it is time to make sense of your data. With all those numbers and aggregated concerns, you are now ready to assess whether it was an efficient school building construction.



Try to answer the following questions as summary to your findings:

	Planned/ Normative
Time	Was the implementation timely? Why?
Cost	Was it value for cost? Why?
Quantity	Was the quantity enough and did it follow standards?
Quality	Is it a quality School building? Why?
Process	Were processes followed? Why or why not?

You probably have an idea how you can send your monitoring reports after the Part B of this manual. This part will further evaluate how you can expand the impact of your monitoring results and ensure that they are sufficiently addressed.

Take note that you may have to prepare two kinds of reports:

- During the monitoring, quick reports and quick feedback mechanism to get real-time updates from the field and response from the implementing agency.
- After the monitoring, a consolidated report should summarize the findings of the monitoring initiative. This can be in the form of a project report or a public presentation.

It is important at this point to remember that in communicating your results, these have to be evidence-based. Thus highlight the results of your checklist and prepare attachments, pictures and other materials necessary to support your conclusions.

### QUICK RESPONSE FEEDBACK MECHANISM

The Quick Response Feedback Mechanism is a reporting system usually established to enable volunteers and monitors to report and update real-time. Since reporting should be quick and fast, you need to take advantage of technology – mobile phones, internet, and so on. The simplest thing you could do is to disseminate your contact numbers to enable your volunteers to effortlessly reach you when they need to do so. On your end, this will help you keep on the loop and make immediate and appropriate responses.

In Bayanihang Eskwela, G-Watch launched 'Text-GWatch', a short messaging service interface that enabled citizens to send in short messages to report about the situation in their communities. After receipt, G-Watch forwarded messages to concerned agencies like DPWH and DepED.

### REPORTING AFTER THE MONITORING

After monitoring, processing, synthesizing, consolidating and evaluating the checklists which you have learned in Part E, you are now ready to present it to your immediate stakeholders that include the government agency partners, as well as the wider public.

You are expected to account for what you have undertaken and consequently, your endeavor is of public interest. Moreover, it is necessary to arrange an exclusive presentation to agency officials to sharpen analysis and enable them to examine and respond to your findings.

### ***Sharing Session***

When the monitors finally convene to discuss what they have finally observed and monitored, it becomes the turning point of the project because this is where all the issues emerge. A sharing session is attended exclusively by the monitoring team, the objective of which is to share their experiences and extract the emerging issues together.

Because the format of a sharing session is ideally informal and relaxed, the participants should be able to feel that they can share without fear of being misinterpreted, rejected or insulted. Your session should have a relaxed atmosphere, free from distractions for reflection.

First, brief the monitors as to what will happen in the sharing session. They would have to be prepared for this; they should bring their field notes and observations to help them in the session. You may have a formal program, but an informal albeit facilitated *kwentuhan* is still best.

The sharing session should answer the following guide questions:

1. How would you describe your monitoring initiative?
2. What challenges have you encountered?
3. What successes have you accomplished?
4. What are the important findings of your monitoring?
5. How can you improve your monitoring?
6. How can the government school building program be improved?

After the team has answered this, you may now summarize this for presentation to the public or the implementing agency.

### ***Problem-Solving Session: Making the Decision-Makers Responsive***

After the sharing session, you need to talk to the implementing agency which is either the DPWH District Engineering Office or the Department of Education Division Office in what we call a problem-solving session. A problem solving session builds trust between your organization and the agency you're monitoring. This is why it is best to get decision-makers to the session to ensure that you will be communicating to the critical persons who may ensure that your monitoring results are translated into reforms.

The main objective of this session is to share the results of your project, especially the emerging issues from the sharing session of the monitors, and looking at how to address these issues *together*. The partnership between you and the agency is crucial, because this helps them realize the value of your monitoring initiative and how their involvement can help themselves improve in the areas you have identified. How the agency commits to addressing your issues is, therefore, your primary success indicator.

Through this session, you must be able to:

- Present the findings of the monitoring program
- Identify the solutions together with the stakeholders and the decision makers

**Do's and don'ts in problem solving sessions with decision makers:**

1. DO remember to include the findings in your sharing session. It helps when the agency sees the point of view of the monitors themselves.
2. DO begin the session with the primary objective of cooperating with the agency. Remember that you're not there to merely point out their problems, but to give them solutions. If you're presenting adverse findings, it makes them feel as if they're not doing their jobs, and puts them on the defensive. Keep them from putting on their defense mechanisms by initiating them into finding solutions, not pointing fingers.
3. DO open your mind to what they say. Many times, what they say are not merely excuses, but factual limitations they have as agencies. It helps if you listen to what they say instead of dismissing them as excuses they can deal with.
4. DON'T blame them. Many times, members of civil society organizations get full of angst when they communicate with the agency, and forget that they're there to solve the problems together. Blaming and pointing do not solve the problem. Resist the temptation to be bitter and just state the facts.

- Get the commitment of the decision makers to implement the solutions

Make sure to conclude the session with some sort of agreement between you and the decision-makers to try to solve the problems raised. Commitment to the issue is the main point of a problem-solving issue. Failing to get a commitment from them may lead to your project's failure.

## Annexes

# ANNEX 1: Bayanihan Eskwela Checklist

## The *Bayanihang Eskwela* Checklist

The **G-Watch Checklist** for the monitoring of school building construction projects under the *Bayanihang Eskwela* is an easy-to-use guide for ordinary, non-technical people. It must be brought during the actual monitoring visits to the project site.

### Components

It consists of six major components, namely the school profile, pre-construction, construction, and post-construction stages, as well as the conduciveness to learning and responsiveness to school need. Under the stages are key activities and/or and indicators.

### Format

The checklist has four columns. The first column contains the “Monitoring Points”, which are in question-form answerable by “yes” or “no”. The monitor simply checks the second or third columns, which are the “Yes” or “No” columns, respectively, to answer the questions. The fourth column asks for “Details” of the answer. Some details are pre-determined in boxes that have to be checked if they have been fulfilled while others

ask for date, place and measure of area or observations and elaboration.

In the “Structure” section of post-construction stage, the first column is also called “Monitoring Points”. It contains the features to look for in a completed school building. The second and third columns contain the (+) and (-) signs, respectively. They must be checked accordingly depending on whether the feature is “present” or “absent” based on the requirements of the Program of Works. The fourth column asks for “Comments and Observations”.

### Coordination and Other Tasks

Refer to the Organizational Structure and Field Monitoring Coordination Plan at the back. The monitor must immediately report any problem encountered during the monitoring. The report must be sent to the School Principal, local DPWH authority, Physical Facilities Coordinator of the DepEd Division or to G-Watch (text 0927-832-3734 or [government\\_watch@yahoo.com](mailto:government_watch@yahoo.com)).

The monitor must also take photos of the construction activity or the structure being constructed during the period of monitoring.

## POINTERS ON MONITORING

### What is monitoring?

Monitoring is active involvement in the implementation of a project, which entails:

- watching the implementation with the main objective of the project in mind
- comparing the plan and standards with the actual accomplishments
- checking particular aspects of the project in its various stages
- recommending remedial actions, if necessary

### Guide monitoring questions:

- At what stage is the project in terms of schedule, budget and required specifications?
- What were accomplished according to the plan and what were the unexpected circumstances?
- What caused problems in the implementation?
- How can the problems be solved? Is it necessary to revise the plan, the schedule or the budget?

### Things to monitor:

- budget
- schedule
- work procedure
- quality of work output

### Don't forget to bring the following:

- G-Watch Checklist
- Copy of the Program of Works
- Notebook and pen
- Camera
- Tape measure

## Organization Structure

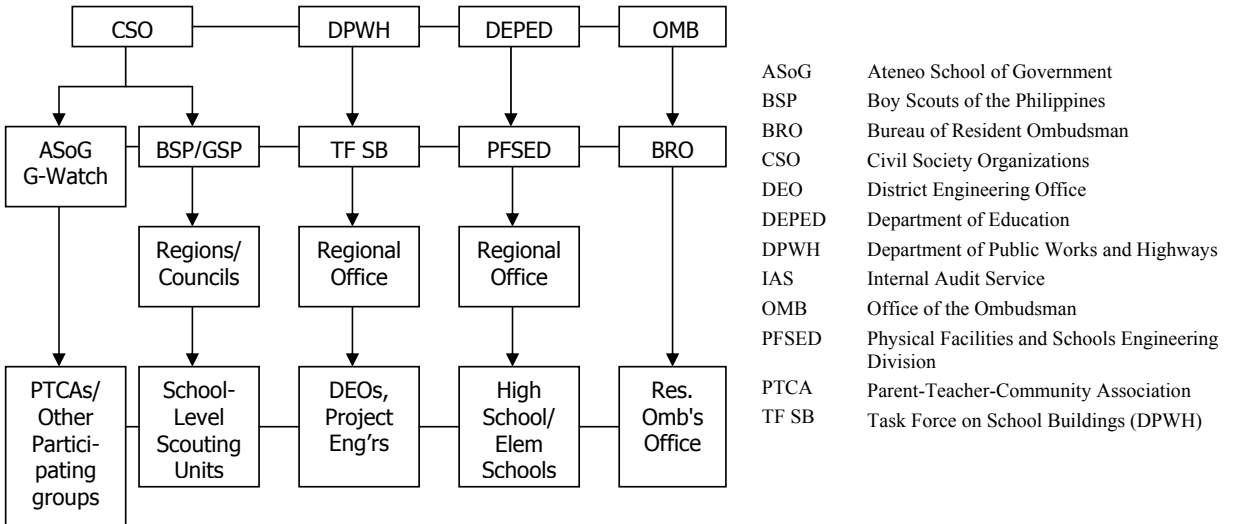

## Monitoring Coordination Plan

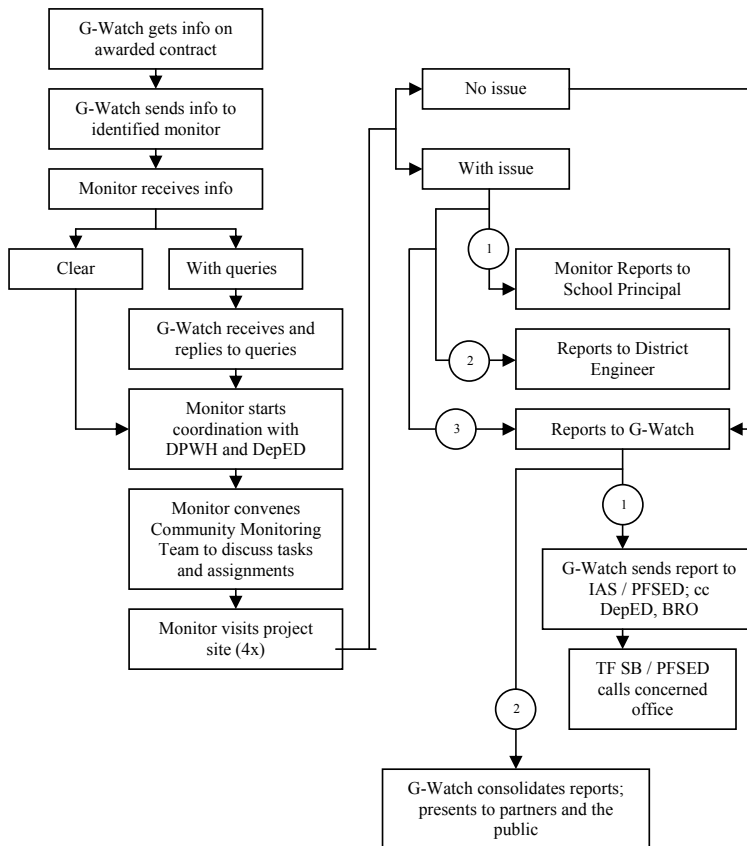

## MONITORING PROFILE

**Name of School:** \_\_\_\_\_  
**Location:** \_\_\_\_\_  
**District:** \_\_\_\_\_  
**Division:** \_\_\_\_\_  
  
**Project:** \_\_\_\_\_  
**Contractor:** \_\_\_\_\_  
**Planned Duration:** \_\_\_\_\_  
**Planned Cost:** \_\_\_\_\_

**Name of Monitor:** \_\_\_\_\_  
  
**Organization:** \_\_\_\_\_  
  
**Sex:** \_\_\_\_\_  
**Age:** \_\_\_\_\_

## GENERAL SCHOOL PROFILE

General School Needs	
Student Population	
Teacher-student Ratio	
Textbook-student Ratio	
Math	
Science	
English	
Filipino	
Classroom-student Ratio	
Seat-student Ratio	
Blackboard-Classroom Ratio	

Educational Development Indicators	
School NAT Score	Year before Last SY: Last SY: This SY:
Completion Rate	Year before Last SY: Last SY: This SY:
Dropout Rate	Year before Last SY: Last SY: This SY:

## PRE-CONSTRUCTION STAGE

Monitoring Points	Yes	No	Details
<b>Activity 1: Site Identification</b>			
1. Did the issue of "property ownership" surface in the project site identification? <i>Lumitaw ba sa site identification ang usapin sa pagmamay-ari ng lupa?</i>			Type of Property <input type="checkbox"/> public property <input type="checkbox"/> donated private property <input type="checkbox"/> expropriated private property
2. Was the site suitable for the project? <i>Angkop ba ang lugar sa proyekto?</i>			<input type="checkbox"/> geographical concern <input type="checkbox"/> environmental concern <input type="checkbox"/> social concern <input type="checkbox"/> other concerns
3. Was there a meeting to discuss issues and concerns? <i>Nagkaroon ba ng pulong upang pag-usapan ang mga isyu?</i>			When: Where: Represented offices/groups: <input type="checkbox"/> DPWH <input type="checkbox"/> PTCA <input type="checkbox"/> DepED <input type="checkbox"/> NGO <input type="checkbox"/> LGU <input type="checkbox"/> DENR <input type="checkbox"/> Barangay Office
<b>Activity 2: Project Meeting</b>			
1. Was there a meeting to finalize project site? <i>Nagkaroon ba ng pulong upang pagdesisyunan ang project site?</i>			When: Where: Represented offices/groups: <input type="checkbox"/> DPWH <input type="checkbox"/> PTCA <input type="checkbox"/> DepED <input type="checkbox"/> NGO <input type="checkbox"/> LGU <input type="checkbox"/> DENR <input type="checkbox"/> Barangay Office
2. Was the project management team formed? <i>Binuo na ba ang project management team?</i>			Name of Project Head:
3. Was the documentation of property ownership in			Type of Documentation

order? <i>Maayos ba ang dokumentasyon ng pagmamay-ari ng lupa?</i>			<input type="checkbox"/> Deed of Donation <input type="checkbox"/> Sale Document <input type="checkbox"/> Annotated Original / Transfer Certificate of Title
<b>Activity 3: Pre-Engineering Survey</b>			
1. Was a pre-engineering survey conducted? <i>Nagsagawa ba ng pre-engineering survey?</i>			When: Lead in the survey: Observations:
2. Did the survey confirm that the building to be constructed fit the land area? <i>Nakumpirma ba ng survey na kasya ang itatayong gusali sa napiling lugar?</i>			Area needed: Area available:
<b>Activity 4: Preparation of the Program of Works</b>			
1. Were you given a copy of the Program of Works? <i>Binigyan ka ba ng kopya ng Program of Works?</i>			Cost: Duration:
2. Did you have difficulty getting a copy of the Program of Works? <i>Nahirapan ka bang himingi ng kopya ng Program of Works?</i>			Elaborate:
3. Is the Program of Works consistent with DepED standards? <i>Ang Program of Works ba ay naaayon sa itinakdang pamantayan ng DepED?</i>			DepED standards: <input type="checkbox"/> cemented floor <input type="checkbox"/> smooth finished walls <input type="checkbox"/> painted walls, ceiling and roofing <input type="checkbox"/> full cathedral-type ceiling (for single-storey) or drop ceiling (for multi-storey) <input type="checkbox"/> complete set of windows (2 facing walls) <input type="checkbox"/> two entrances with doors <input type="checkbox"/> complete electrical wires and fixtures <input type="checkbox"/> roofing or weather protection <input type="checkbox"/> blackboard
<b>Activity 5: Site Inspection</b>			
1. Was a site inspection conducted? <i>Nagsagawa ba ng site inspection?</i>			When: Where: Represented offices/groups: <input type="checkbox"/> DPWH <input type="checkbox"/> PTCA <input type="checkbox"/> DepED <input type="checkbox"/> NGO <input type="checkbox"/> LGU <input type="checkbox"/> DENR <input type="checkbox"/> Barangay Office
2. Did DPWH give orientation on project plans during site inspection? <i>Nagsagawa ba ng project orientation?</i>			When:
3. Was the information given in the orientation consistent with the Program of Works? <i>Ang impormasyon bang ibinigay sa orientation ay naaayon sa nakasaad sa Program of Works?</i>			Inconsistencies (if any):
<b>Activity 6: Bidding</b>			
1. Was bidding conducted for the project? <i>Nagsagawa ba ng bidding para sa proyekto?</i>			If yes, When: Where: Who presided:  If no, Mode of procurement used:  Amount of Contract:  Name of Contractor:
2. Were there issues and concerns raised? <i>May mga usapin bang tinalakay?</i>			Elaborate:
3. Was post-qualification conducted?			Lowest Calculated Responsive Bids:

<i>Nagsagawa ba ng post-qualification?</i>			1. 2. 3.
4. Did you do your own checking of contractor's capacity? <i>Nagsagawa ka ba ng sariling pagsisiyasat sa kapasidad ng contractor?</i>			Findings:
5. Was the Notice to Award sent to the winning bidder? <i>Naipadala ba ang Notice of Award sa nanalong bidder?</i>			When:
6. Did the winning bidder send Letter of Acceptance? <i>Nagbigay ba ng Letter of Acceptance ang nanalong bidder?</i>			When:
7. Was the Notice to Proceed sent to the winning bidder? <i>Naipadala ba ang Notice to Proceed sa nanalong bidder?</i>			When:

## CONSTRUCTION STAGE

Monitoring Points	Yes	No	Details
<b>Activity 1: Earthworks and Excavation</b>			
1. Were garbage, plants, remains of old structures, and other obstructions removed and disposed of properly? <i>Maayos bang tinanggal at itinapon ang mga basura, halaman, tira ng lumang istruktura at iba pang sagabal sa konstruksyon?</i>			Observations:
2. Were there items (e.g. structures, trees) that had been unnecessarily damaged? <i>Mayroon bang bagay, istruktura o puno na aksidenteng nasira?</i>			What: Who is responsible for the damage?
3. Was the excavation area in accordance with the plan in the Program of Works? <i>Ang sukat ba ng excavation ay ayon sa plano sa Program of Works?</i>			Planned Area in Program of Works: Actual Excavated Area:
4. Did the excavation disturb any slopes? <i>May nasira bang talilis dahil sa paghuhukay?</i>			Observations:
5. Was the excavated surface smooth and uniform? <i>Patag at pantay ba ang ibabaw ng hukay?</i>			Observations:
6. Were the excavated materials disposed of properly? <i>Itinapon ba nang maayos ang mga nahukay?</i>			Observations:
7. Were the excess materials (e.g. rocks and boulders) used as backfill materials? <i>Ginamit bang backfill materials ang mga bato?</i>			If yes, was there permission from the Project Engineer?
<b>Activity 2: Concrete Works</b>			
1. Was Type A or Portland Cement used? <i>Type A o Portland Cement ba ang ginamit?</i>			
2. Were the bags of cement stored properly? <i>Nakaimbak ba nang maayos ang mga bag ng semento?</i>			Indicators: <input type="checkbox"/> Bags of cement may get wet in the storage room <input type="checkbox"/> Storage room has cracks or openings between walls and roofs <input type="checkbox"/> Flooring is above ground <input type="checkbox"/> Cement bags are stacked close together  Observations:
3. Were cements that already solidified or which contain lumps of caked cement still being used? <i>Ginagamit pa rin ba ang mga sementong namuo-muo at</i>			Observations:

<i>nagkatipak-tipak na?</i>					
4. Were cements salvaged from discarded or used bags still being used? <i>Ginagamit pa rin ba ang mga tira-tirang semento?</i>			Observations:		
5. Did they mix cement with clean water? <i>Malinis na tubig ba ang hinahalo sa semento?</i>			Indicators: <input type="checkbox"/> no oil / no slat / no acid / no álcali / no grass  Observations:		
6. Were quality coarse aggregates (gravel) used? <i>Tamang kalidad ba ang ginagamit na graba?</i>			Indicators: <input type="checkbox"/> Color is blue, not brown / Clean, no mixture of soil or clay / Hard, strong and durable; do not break easily / Free from any adherent coatings or crystals  Observations:		
7. Were quality fine aggregates (sands) used? <i>Tamang kalidad ba ang ginagamit na buhangin?</i>			Indicators: <input type="checkbox"/> Must come from the river, not sea (color: black) / Sands from different sources are not combined together  Observations:		
8. Was the correct proportion of water, cement and aggregates followed in the construction of columns and beams? <i>Sinusunod ba ang tamang panumbasan sa paghahalo ng tubig, semento at aggregates?</i>			Indicators: <input type="checkbox"/> Water: 15%-20% / Cement: 7%-14% / Aggregates: 66%-78%  Observations:		
9. Were the materials in good shape? <i>Nasa maayos na kondisyon ba ang mga materyales?</i>			Indicators: <input type="checkbox"/> no rust / no cracks and laminations / no surface irregularities or mill scale  Observations:		
10. Were the type, size and quantity of materials in accordance with the Program of Works? <i>Ayon ba sa Program of Works ang uri, sukat at bilang ng materyales?</i>			Type	Size	Qty
11. Were the materials stored properly? <i>Maayos ba ang pag-iimbak sa mga materyales?</i>			Indicators: <input type="checkbox"/> Placed on a platform or above ground <input type="checkbox"/> It does not pose danger or injury to people  Observations:		
<b>Activity 3: Masonry</b>					
1. Was the size of hollow blocks used in accordance with the Program of Works? <i>Ayon ba sa Program of Works ang sukat ng hollow blocks?</i>			Program of Works: Actual:  Observations:		
2. Was the size of steel bars used in accordance with the Program of Works? <i>Ayon ba sa Program of Works ang sukat ng steel bars?</i>			Program of Works: Actual:  Observations:		
3. Was the size of wires used in accordance with the Program of Works? <i>Ayon ba sa Program of Works ang sukat ng wires?</i>			Program of Works: Actual:  Observations:		
<b>Activity 4: Carpentry</b>					
1. Did the contractor buy and deliver the materials needed? <i>Ang contractor ba ang bumili at naghatid ng mga materyales?</i>			Observations:		
2. Did the contractor buy the right number, size, and shape of materials as stated in the Program of Works? <i>Ayon ba sa Program of Works ang bilang, sukat at hugis ng mga biniling materyales?</i>			Observations:		

3. Were the timber materials in good condition? <i>Ang mga kahoy ba ay nasa maayos na kondisyon?</i>			Indicators: <input type="checkbox"/> no loose knots / no split / no worm hole / no decay / no warp / no ring separation
4. Were the materials stored properly? <i>Maayos ba ang pagkaimbak ng mga materyales?</i>			
<b>Activity 5: Painting</b>			
1. Was the paint of good quality? <i>Maayos ba ang kalidad ng pintura?</i>			Indicators: <input type="checkbox"/> no excessive setting / no curdling / no caking / no gelling or thickening / no color separation / no lumps and skins  Observations:
2. Did the paint brush easily? <i>Madali bang lumapat ang pintura?</i>			Indicators: <input type="checkbox"/> with good levelling properties / no running or sagging when applied to smooth vertical surface  Observations:

## POST-CONSTRUCTION STAGE

Monitoring Points	Yes	No	Details
<b>Process</b>			
Was the School Principal consulted on the Plans and Program of Works? <i>Kinunsulta ba ang School Principal sa plano at Program of Works?</i>			
Did DPWH District Engineering Office provide copy of Program of Works prior to construction? <i>Nagbigay ba ng kopya ng Program of Works bago magsimula ang konstruksyon?</i>			
Was the schedule announced prior to construction? <i>Ipinaalam ba ang schedule bago magsimula ang konstruksyon?</i>			When:
Was construction completed within schedule? <i>Natapos ba ang konstruksyon ayon sa schedule?</i>			Start: End:
Was a joint Final Inspection conducted? <i>Nagsagawa ba ng joint Final Inspection?</i>			When: Inspection Team members: <input type="checkbox"/> DPWH <input type="checkbox"/> DepED <input type="checkbox"/> Barangay <input type="checkbox"/> PTCA <input type="checkbox"/> CSO
Were defective works rectified within 15 days? <i>Naayos ba ang mga maling trabaho sa loob ng 15 araw?</i>			Defects rectified: 1. 2. 3.
Was construction completed according to specifications? <i>Natapos ba ang konstruksyon ayon sa mga takdang specifications?</i>			Lacking: 1. 2. 3.

Monitoring Points	( - )	( + )	Comments / Observations
<b>Structure</b>			
Concreting Wall & Column Footings Tie Beams/Beams Floor Slab Columns			
Roofing & Accessories Trusses/Rafters Purlins			

Corrugated GI Sheet Teckscrew			
Doors and Windows Panel Doors Flush Doors Steel Doors Steel Casement Windows Jalousie Windows			
Plumbing Works Pipes Fittings Fixtures			
Painting Works Roofings Interior & Exterior Walls Ceiling Doors & Windows			
Electrical Fixtures Rough-ins Wires Fixtures Bulbs/Fluorescents			

### CONDUCTIVENESS TO LEARNING

Monitoring Points	YES	NO	Comments / Observations
<b>Indicators</b>			
<u>Ventilation:</u> Are the classrooms well-ventilated? <i>Maaliwalas ba ang loob ng mga silid-aralan?</i>			
<u>Lighting:</u> Are the classrooms sufficiently lighted? <i>Sapat ba ang liwanag sa loob ng mga silid-aralan?</i>			
<u>Space:</u> Are the classrooms spacious enough for the students? <i>Sapat ba ang lawak ng mga silid-aralan para sa mga estudyante?</i>			
<u>Sanitation:</u> Was the school building site sanitary? <i>Malinis ba ang pinagtayuan ng mga silid-aralan?</i>  Is the school building free from health threats? <i>Ang mga silid-aralan ba ay walang banta sa kalusugan?</i>			What are the threats?  How are they addressed?
<u>Safety:</u> Does the school building have safety features?			<input type="checkbox"/> Emergency exit <input type="checkbox"/> Security Grills <input type="checkbox"/> Ramp

<p><i>Mayroon bang safety features ang silid-aralan?</i></p> <p>Were there safety risks in the construction of the SBP? <i>Nagkaroon ba ng mga banta sa kaligtasan noong itinatayo ang mga silid-aralan?</i></p>			
<p><u>Others:</u> What other aspects of the school building is either commendable or should still be improved? <i>Ano pang aspeto ng silid-aralan ang kapuri-puri o kaya naman ay dapat pa ipagbuti?</i></p>	<p>Commendable:</p> <p>Still needs improvements:</p>		

**RESPONSIVENESS TO SCHOOL NEED**

Monitoring Points	YES	NO	Comments / Observations
<p>Is the school under the Red and Black Category (Red – Equal to or more than 56 students per classroom; Black – No classroom available)? <i>Nasa Red and Black Category ba ang eskwelahan, na nangangahulugang nasa 56 o higit pa ang estudyante kada silid-aralan o kaya ay walang silid-aralan sa eskwelahan?</i></p>			<p>Number of Classrooms: _____            Number of Makeshift Classrooms: _____            Number of Condemnable Classrooms: _____            Number of Buildings: _____            Number of Condemnable Buildings: _____</p>
<p>Is the design of the classroom appropriate for the school environment? <i>Naangkop ba ang disenyo ng silid-aralan sa kapaligiran ng eskwelahan?</i></p>			
<p>Is the design of the classroom appropriate for the community's culture? <i>Naangkop ba ang disenyo ng silid-aralan sa kultura ng komunidad?</i></p>			

**IMMEDIATE CONCERNS OF THE SCHOOL**

<p><u>Others:</u> What are the school's immediate concerns? <i>Ano pa ang ibang mahahalagang pangangailangan ng eskwelahan?</i></p>
---

## ANNEX 2: Department of Education School Building Design

### SCHOOL BUILDING DESIGNS

Department of Education  
Physical Facilities and Schools Engineering Division

#### DESIGN CONSIDERATIONS

- Function and needs of its user
- Economy in construction, utilization and maintenance
- Human dimensions
- Applicable building codes

#### ONE STOREY DESIGNS (1-3 Classroom design)

##### Basic Features

A. Basic Structure	Reinforced concrete
B. Roof Framing	Steel Rafters and Purlins
C. Exterior Finish	
1. Roof	Ga. 26 Ordinary Corrugated G.I. Sheet
2. Eaves	Without Exterior Ceiling
3. Walls	4" CHB with plain cement plaster paint finish
4. Windows	Clear Glass Jalousie Windows
5. Doors	Flush Doors
D. Interior Finish	
1. Flooring	Reinforced concrete slab with plain cement finish
2. Ceiling	1/4" thk Ordinary Plywood
3. Partition	4" CHB with plain cement plaster paint finish
E. Electrical Provisions	Complete with basic lighting fixtures and outlets

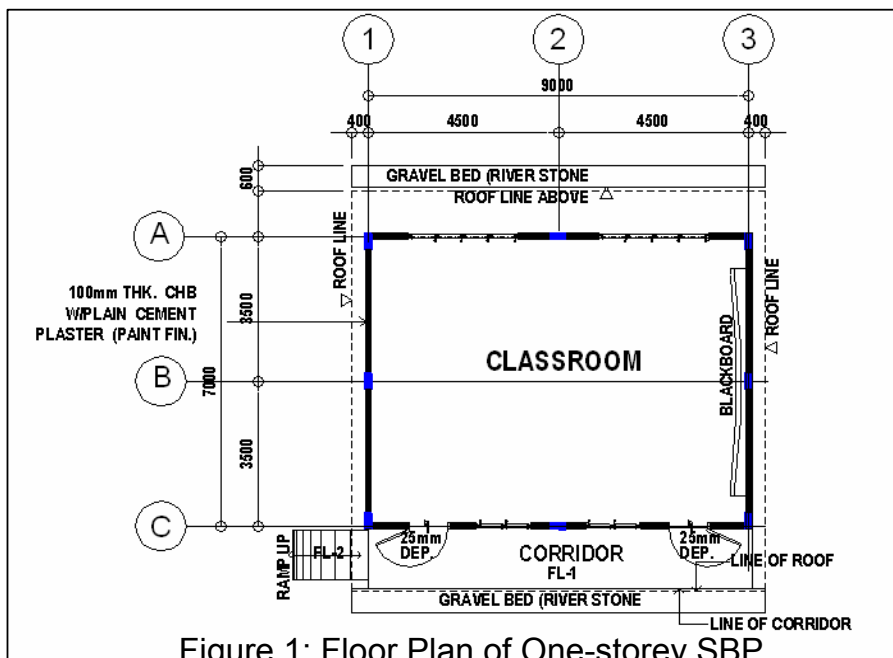

Figure 1: Floor Plan of One-storey SBP

Figure 2: Cross Section View of One-Storey SBP

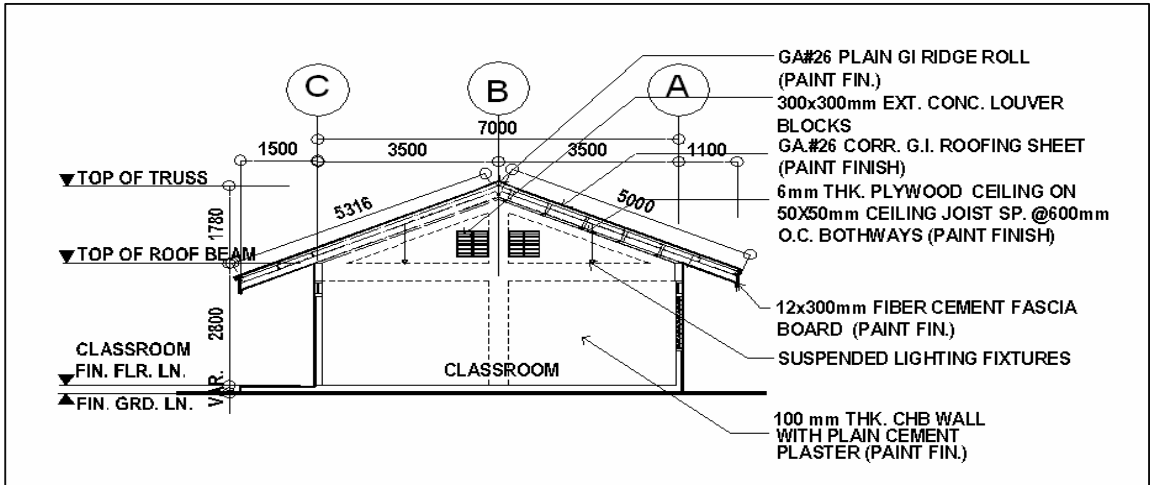

Figure 3: Front Elevation of One-Storey SBP

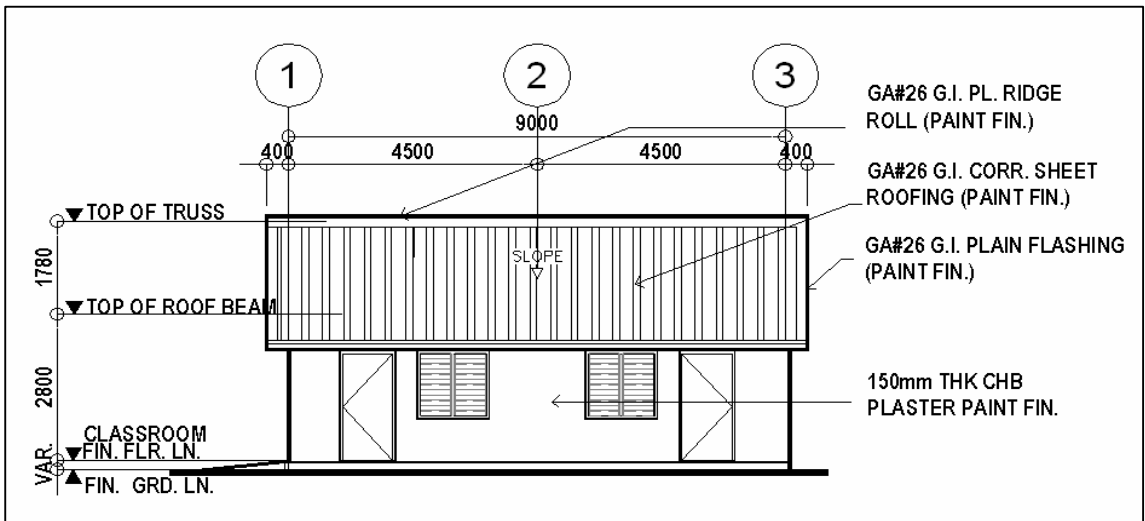
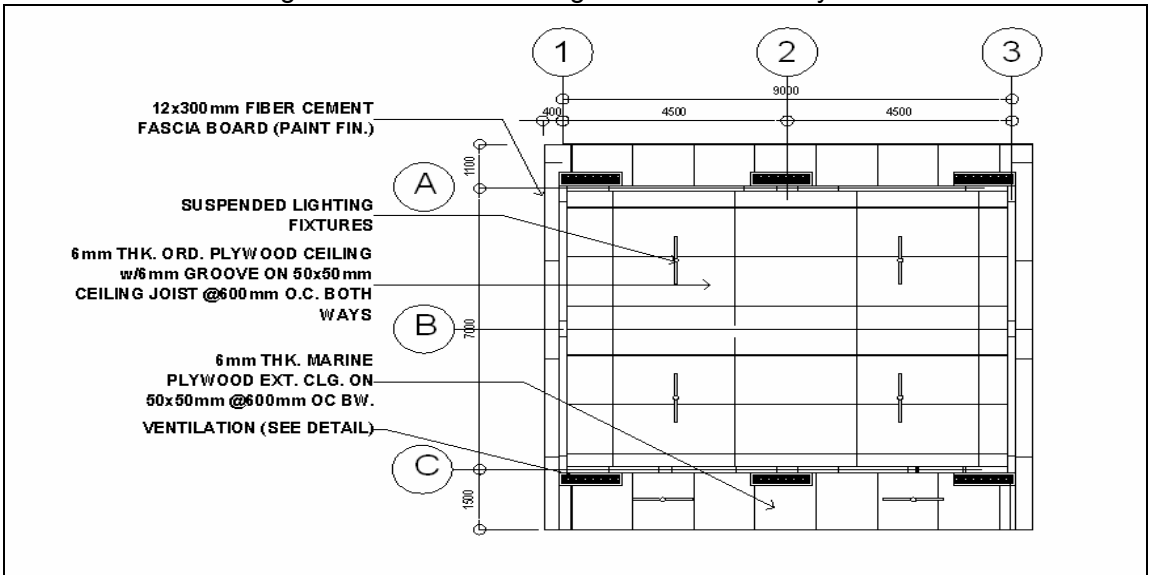

Figure 4: Reflected Ceiling Plan of One-Storey SBP



## TWO/THREE STOREY DESIGNS

### Basic Features

A. Basic Structure	Reinforced concrete
B. Roof Framing	Steel Trusses and Purlins
C. Exterior Finish	
1. Roof	Ga. 26 Ordinary Corrugated G.I. Sheet
2. Eaves	¼" thk Marine Plywood
3. Walls	6" CHB with plain cement plaster paint finish
4. Windows	Clear Glass Jalousie Windows
5. Doors	Solid Panel Doors
D. Interior Finish	
1. Flooring	Reinforced concrete slab with plain cement finish
2. Ceiling	¼" thk Ordinary Plywood / Ficem Board
3. Partition	6" CHB with plain cement plaster paint finish
E. Electrical Provisions	Complete with basic lighting fixtures and outlets



Figure 5: Floor Plan of a 2/3-Storey SBP



Figure 6: Front Elevation of a 2/3-Storey SBP

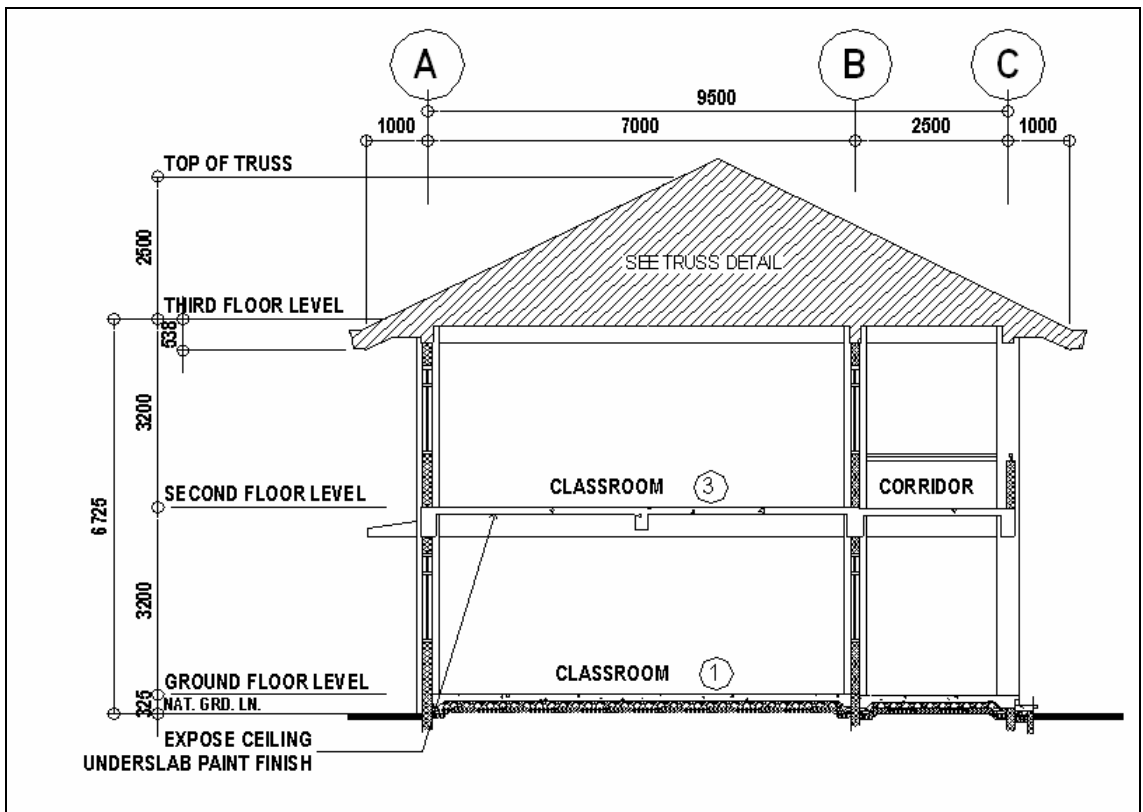

Figure 7: Cross Section of a 2/3-Storey SBP

## ANNEX 3: The *Bayanihang Eskwela* Processing Template

### The *Bayanihang Eskwela* Processing Template

The **Bayanihang Eskwela Processing Template** is used to consolidate the results of your monitoring with the use of your Bayanihang Eskwela checklist. Tally the results of your team’s checklist using the tables below. Read the instruction carefully for each part, and answer according to what is asked for.

#### MONITORING PROFILE

<b>Name of School:</b> _____	<b>Name of Monitors:</b> _____
<b>Location:</b> _____	_____
<b>District:</b> _____	_____
<b>Division:</b> _____	_____
<b>Project:</b> _____	_____
<b>Contractor:</b> _____	_____
<b>Planned Duration:</b> _____	_____
<b>Planned Cost:</b> _____	<b>TOTAL # of Monitors:</b> _____

#### GENERAL SCHOOL PROFILE

The first part of the checklist on the general school needs will ask you to assess whether the school is faring well or not in the identified items. Fill up the third column, and then assess whether there is a ‘shortage’, ‘sufficient’ or a ‘surplus’ of the resources that your schools needs.

GENERAL SCHOOL NEEDS	Standard/ Ideal Number	Actual School Data	Observation (Shortage, Sufficient, Surplus)
Student Population	--		
Teacher-student Ratio	1:35		
Textbook-student Ratio			
Math	1:1		
Science	1:1		
English	1:1		
Filipino	1:1		
Classroom-student Ratio	1:45		
Seat-student Ratio	1:1		
Classroom- blackboard Ratio	1:1		

Fill out the second column where needed (i.e. this year's national average for completion and dropout rate). Insert your school's data in 3<sup>rd</sup> column, and then assess whether it is above or below average/ideal after comparing it to the data in the 2<sup>nd</sup> column and insert your observation in the 4<sup>th</sup> column. Lastly, on the 5<sup>th</sup> column, assess whether the figures are improving, declining, or if remains stagnant.

Educational Development Indicators	Ideal/Average Number	Actual School Data	Observation Against Ideal Number	Improving, Stagnant, or Declining
School NAT Score	75 % (Passing Grade)	Year before Last SY: Last SY: This SY:		
Completion Rate	National Average Year before Last SY: Last SY: This SY:	Year before Last SY: Last SY: This SY:		
Dropout Rate	National Average Year before Last SY: Last SY: This SY:	Year before Last SY: Last SY: This SY:		

#### PRE-CONSTRUCTION STAGE

The first column contains the "Monitoring Points", which are in question-form answerable by "yes" or "no". For the second and third column, you will tally the number of 'Yes' and the Number of 'No' that your monitors answered in their checklists. The fourth column asks for "Details" of the answer.

Monitoring Points	# of Yes	# of No	Explanation of Deviation
<b>Activity 1: Site Identification</b>			
1. Did the issue of "property ownership" surface in the project site identification? <i>Lumitaw ba sa site identification ang usapin sa pagmamay-ari ng lupa?</i>			
2. Was the site suitable for the project? <i>Angkop ba ang lugar sa proyekto?</i>			
3. Was there a meeting to discuss issues and concerns? <i>Nagkaroon ba ng pulong upang pag-usapan ang mga isyu?</i>			
<b>Activity 2: Project Meeting</b>			
1. Was there a meeting to finalize project site? <i>Nagkaroon ba ng pulong upang pagdesisyon ang project site?</i>			
2. Was the project management team formed? <i>Binuo na ba ang project management team?</i>			
3. Was the documentation of property ownership in order?			

<i>Maayos ba ang dokumentasyon ng pagmamay-ari ng lupa?</i>			
<b>Activity 3: Pre-Engineering Survey</b>			
1. Was a pre-engineering survey conducted? <i>Nagsagawa ba ng pre-engineering survey?</i>			
2. Did the survey confirm that the building to be constructed fit the land area? <i>Nakumpirma ba ng survey na kasya ang itatayong gusali sa napiling lugar?</i>			
<b>Activity 4: Preparation of the Program of Works</b>			
1. Were you given a copy of the Program of Works? <i>Binigyan ka ba ng kopya ng Program of Works?</i>			
2. Did you have difficulty getting a copy of the Program of Works? <i>Nahirapan ka bang himingi ng kopya ng Program of Works?</i>			
3. Is the Program of Works consistent with DepED standards? <i>Ang Program of Works ba ay naaayon sa itinakdang pamantayan ng DepED?</i>			
<b>Activity 5: Site Inspection</b>			
1. Was a site inspection conducted? <i>Nagsagawa ba ng site inspection?</i>			
2. Did DPWH give orientation on project plans during site inspection? <i>Nagsagawa ba ng project orientation?</i>			
3. Was the information given in the orientation consistent with the Program of Works? <i>Ang impormasyon bang ibinigay sa orientation ay naaayon sa nakasaad sa Program of Works?</i>			
<b>Activity 6: Bidding</b>			
1. Was bidding conducted for the project? <i>Nagsagawa ba ng bidding para sa proyekto?</i>			
2. Were there issues and concerns raised? <i>May mga usapin bang tinalakay?</i>			
3. Was post-qualification conducted? <i>Nagsagawa ba ng post-qualification?</i>			
4. Did you do your own checking of contractor's capacity? <i>Nagsagawa ka ba ng sariling pagsisiyasat sa kapasidad ng contractor?</i>			
5. Was the Notice to Award sent to the winning bidder? <i>Naipadala ba ang Notice of Award sa nanalong bidder?</i>			
6. Did the winning bidder send Letter of Acceptance? <i>Nagbigay ba ng Letter of Acceptance ang nanalong bidder?</i>			
7. Was the Notice to Proceed sent to the winning bidder? <i>Naipadala ba ang Notice to Proceed sa nanalong bidder?</i>			

## CONSTRUCTION STAGE

The first column contains the "Monitoring Points", which are in question-form answerable by "yes" or "no". For the second and third column, you will tally the number of 'Yes' and the Number of 'No' that your monitors answered in their checklists. The fourth column asks for "Details" of the answer.

Monitoring Points	# of Yes	# of No	Details
<b>Activity 1: Earthworks and Excavation</b>			
1. Were garbage, plants, remains of old structures, and other obstructions removed and disposed of properly? <i>Maayos bang tinanggal at itinapon ang mga basura, halaman, tira ng lumang istruktura at iba pang sagabal sa konstruksyon?</i>			
2. Were there items (e.g. structures, trees) that had been unnecessarily damaged? <i>Mayroon bang bagay, istruktura o puno na aksidenteng nasira?</i>			
3. Was the excavation area in accordance with the plan in the Program of Works? <i>Ang sukat ba ng excavation ay ayon sa plano sa Program of Works?</i>			
4. Did the excavation disturb any slopes? <i>May nasira bang talilis dahil sa paghuhukay?</i>			
5. Was the excavated surface smooth and uniform? <i>Patag at pantay ba ang ibabaw ng hukay?</i>			
6. Were the excavated materials disposed of properly? <i>Itinapon ba nang maayos ang mga nahukay?</i>			
7. Were the excess materials (e.g. rocks and boulders) used as backfill materials? <i>Ginamit bang backfill materials ang mga bato?</i>			
<b>Activity 2: Concrete Works</b>			
1. Was Type A or Portland Cement used? <i>Type A o Portland Cement ba ang ginamit?</i>			
2. Were the bags of cement stored properly? <i>Nakaimbak ba nang maayos ang mga bag ng semento?</i>			
3. Were cements that already solidified or which contain lumps of caked cement still being used? <i>Ginagamit pa rin ba ang mga sementong namuo-muo at nagkatipak-tipak na?</i>			
4. Were cements salvaged from discarded or used bags still being used? <i>Ginagamit pa rin ba ang mga tira-tirang semento?</i>			
5. Did they mix cement with clean water? <i>Malinis na tubig ba ang hinahalo sa semento?</i>			
6. Were quality coarse aggregates (gravel) used? <i>Tamang kalidad ba ang ginagamit na graba?</i>			
7. Were quality fine aggregates (sands) used? <i>Tamang kalidad ba ang ginagamit na buhangin?</i>			
8. Was the correct proportion of water, cement and aggregates followed in the construction of columns and beams? <i>Sinusunod ba ang tamang panumbasan sa paghahalo ng tubig, semento at aggregates?</i>			
9. Were the materials in good shape? <i>Nasa maayos na kondisyon ba ang mga materyales?</i>			
10. Were the type, size and quantity of materials in accordance with the Program of Works? <i>Ayon ba sa Program of Works ang uri, sukat at bilang ng materyales?</i>			
11. Were the materials stored properly? <i>Maayos ba ang pag-iimbak sa mga materyales?</i>			

<b>Activity 3: Masonry</b>			
1. Was the size of hollow blocks used in accordance with the Program of Works? <i>Ayon ba sa Program of Works ang sukat ng hollow blocks?</i>			
2. Was the size of steel bars used in accordance with the Program of Works? <i>Ayon ba sa Program of Works ang sukat ng steel bars?</i>			
3. Was the size of wires used in accordance with the Program of Works? <i>Ayon ba sa Program of Works ang sukat ng wires?</i>			
<b>Activity 4: Carpentry</b>			
1. Did the contractor buy and deliver the materials needed? <i>Ang contractor ba ang bumili at naghatid ng mga materyales?</i>			
2. Did the contractor buy the right number, size, and shape of materials as stated in the Program of Works? <i>Ayon ba sa Program of Works ang bilang, sukat at hugis ng mga biniling materyales?</i>			
3. Were the timber materials in good condition? <i>Ang mga kahoy ba ay nasa maayos na kondisyon?</i>			
4. Were the materials stored properly? <i>Maayos ba ang pagkaimbak ng mga materyales?</i>			
<b>Activity 5: Painting</b>			
1. Was the paint of good quality? <i>Maayos ba ang kalidad ng pintura?</i>			
2. Did the paint brush easily? <i>Madali bang lumapat ang pintura?</i>			

<b>POST-CONSTRUCTION STAGE</b>
--------------------------------

The first column contains the “Monitoring Points”, which are in question-form answerable by “yes” or “no”. For the second and third column, you will tally the number of ‘Yes’ and the Number of ‘No’ that your monitors answered in their checklists. The fourth column asks for “Details” of the answer.

<b>Monitoring Points</b>	<b># of Yes</b>	<b># of No</b>	<b>Details</b>
<b>Process</b>			
Was the School Principal consulted on the Plans and Program of Works? <i>Kinunsulta ba ang School Principal sa plano at Program of Works?</i>			
Did DPWH District Engineering Office provide copy of Program of Work prior to construction? <i>Nagbigay ba ng kopya ng Program of Work bago magsimula ang konstruksyon?</i>			
Was the schedule announced prior to construction? <i>Ipinaalam ba ang schedule bago magsimula ang konstruksyon?</i>			
Was construction completed within schedule? <i>Natapos ba ang konstruksyon ayon sa schedule?</i>			
Was a joint Final Inspection conducted? <i>Nagsagawa ba ng joint Final Inspection?</i>			
Were defective works rectified within 15 days? <i>Naayos ba ang mga maling trabaho sa loob ng 15 araw?</i>			
Was construction completed according to specifications? <i>Natapos ba ang konstruksyon ayon sa mga takdang specifications?</i>			

Here in the “Structure” section of post-construction stage, the first column is also called “Monitoring Points”. It contains the features to look for in a completed school building. The second and third columns contain the (+) and (-) signs, respectively. They must be checked accordingly depending on whether the feature is “present” or “absent” based on the requirements of the Program of Work. The fourth column asks you to answer whether the SBP is generally good, average or generally bad. Please aggregate your comments and observations as well.

Monitoring Points	# of (-)	# of (+)	Quality (Good/Average/Bad)
<b>Structure</b>			
Concreting Wall & Column Footings Tie Beams/Beams Floor Slab Columns			
Roofing & Accessories Trusses/Rafters Purlins Corrugated GI Sheet Teckscrew			
Doors and Windows Panel Doors Flush Doors Steel Doors Steel Casement Windows Jalousie Windows			
Plumbing Works Pipes Fittings Fixtures			
Painting Works Roofings Interior & Exterior Walls Ceiling Doors & Windows			
Electrical Fixtures Rough-ins Wires Fixtures Bulbs/Fluorescents			

### CONDUCTIVENESS TO LEARNING

For this part, follow the same instruction as in the Construction Stage: The first column contains the “Monitoring Points”, which are in question-form answerable by “yes” or “no”. For the second and third column, you will tally the number of ‘Yes’ and the number of ‘No’ that your monitors answered in their checklists. The fourth column asks for “Details” of the answer.

Monitoring Points	# of YES	# of NO	Comments / Observations
<b>Indicators</b>			
<u>Ventilation:</u> Are the classrooms well-ventilated? <i>Maaliwalas ba ang loob ng mga silid-aralan?</i>			

<p><u>Lighting:</u> Are the classrooms sufficiently lighted? <i>Sapat ba ang liwanag sa loob ng mga silid-aralan?</i></p>			
<p><u>Space:</u> Are the classrooms spacious enough for the students? <i>Sapat ba ang lawak ng mga silid-aralan para sa mga estudyante?</i></p>			
<p><u>Sanitation:</u> Was the school building site sanitary? <i>Malinis ba ang pinagtayuan ng mga silid-aralan?</i></p> <p>Is the school building free from health threats? <i>Ang mga silid-aralan ba ay walang banta sa kalusugan?</i></p>			
<p><u>Safety:</u> Does the school building have safety features? <i>Mayroon bang safety features ang silid-aralan?</i></p> <p>Were there safety risks in the construction of the SBP? <i>Nagkaroon ba ng mga banta sa kaligtasan noong itinatayo ang mga silid-aralan?</i></p>			
<p><u>Others:</u> What other aspects of the school building is either commendable or should still be improved? <i>Ano pang aspeto ng silid-aralan ang kapuri-puri o kaya naman ay dapat pa ipagbuti?</i></p>	<p>Commendable:</p> <p>Still needs improvements:</p>		

### RESPONSIVENESS TO SCHOOL NEED

The first column contains the “Monitoring Points”, which are in question-form answerable by “yes” or “no”. For the second and third column, you will tally the number of ‘Yes’ and the Number of ‘No’ that your monitors answered in their checklists. The fourth column asks for “Details” of the answer.

Monitoring Points	# of YES	# of NO	Comments / Observations
Is the school under the Red and Black Category (Red – Equal to or more than 56 students per classroom; Black – No classroom available)?			

<i>Nasa Red and Black Category ba ang eskwelahan, na nangangahulugang nasa 56 o higit pa ang estudyante kada silid-aralan o kaya ay walang silid-aralan sa eskwelahan?</i>			
Is the design of the classroom appropriate for the school environment? <i>Naangkop ba ang disenyo ng silid-aralan sa kapaligiran ng eskwelahan?</i>			
Is the design of the classroom appropriate for the community's culture? <i>Naangkop ba ang disenyo ng silid-aralan sa kultura ng komunidad?</i>			

### IMMEDIATE CONCERNS OF THE SCHOOL

Kindly list down the answers of your monitoring team members in the box below

<p>Others: What are the school's immediate concerns? <i>Ano pa ang ibang mahahalagang pangangailangan ng eskwelahan?</i></p> <p>1. _____</p> <p>2. _____</p> <p>3. _____</p> <p>4. _____</p>
--

### GENERAL FINDINGS

Using the data you have aggregated above, try to answer the questions below as faithfully as possible to what you have monitored. Explain briefly the reason for you answer

<b>Variables</b>	<b>Planned/ Normative</b>
<b>Time</b>	Was the implementation timely? Why?
<b>Cost</b>	Was it value for cost? Why?
<b>Quantity</b>	Was the quantity enough and did it follow standards?
<b>Quality</b>	Is it a quality School building? Why?
<b>Process</b>	Were processes followed? Why or why not?





**Ateneo School of Government**  
The Graduate School of Leadership and Public Service

# GOVERNMENTWATCH

JOINT GOVERNMENT-CITIZEN ACTION FOR GOOD GOVERNANCE

The Bayanihang Eskwela Manual is an easy-to-use toolkit that guides the setting and implementation of a community-based monitoring of government school building projects (SBP) using the tested processes and tools of Bayanihang Eskwela, a joint monitoring initiative of the Ateneo School of Government through its Government Watch Program, in partnership with the Department of Education, Department of Public Works and Highways (DPWH), the Girl Scouts of the Philippines, the Boy Scouts of the Philippines and the Office of the Ombudsman.

Recognizing that school building construction monitoring may seem daunting and technical, this Manual is made simple and easy-to-understand for any concerned citizen organization that wishes to engage DepEd and DPWH in monitoring school-building projects (SBP). It also aims to assist government project engineers in involving community participation in SBP implementation.

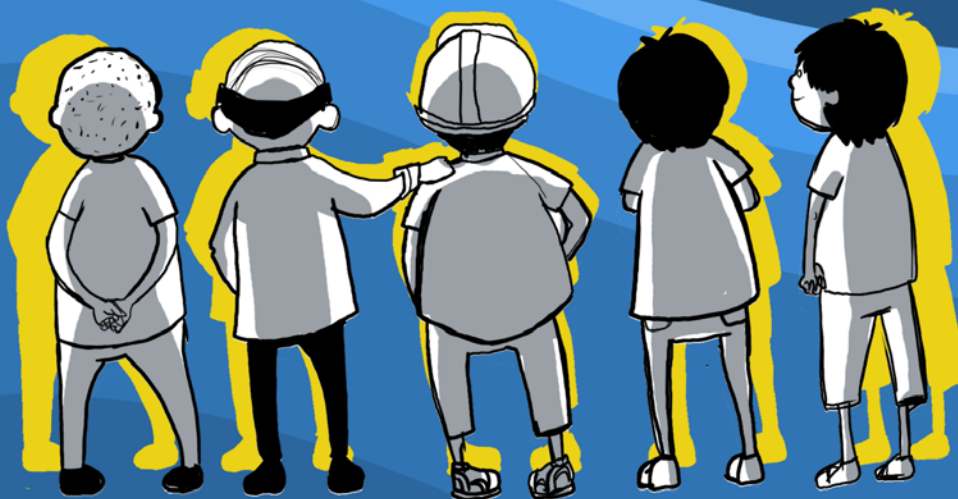

G-Watch (Government Watch) is a social accountability program of the Ateneo School of Government that aims to contribute in enhancing transparency and accountability in Philippine governance through constructive engagement between citizen organizations and government in performance monitoring. Established in 2000, G-Watch has developed and tested monitoring tools in monitoring Critical service deliveries and governance processes such as textbook delivery, school building project, public works, medicines procurement, disaster relief goods distribution, and recently, electoral development budget and human rights compliance. It has ongoing engagement with key national government agencies, accountability institutions and has recently started engaging local governance with its G-Watch Localization Program.

Address: Ateneo School of Government, Pacifico Ortiz Hall, Social Development Complex,  
Ateneo de Manila University, Loyola Heights, Quezon City  
Telefax: (02) 920-2920 or (02) 426-6001 local 4644  
Email: [government\\_watch@yahoo.com](mailto:government_watch@yahoo.com)